



Historical explanation of the origin of the herpetofauna of Mexico

Explicación histórica del origen de la herpetofauna de México

Oscar Flores-Villela^{1,2*} and Elizabeth A. Martínez-Salazar³

¹Museo de Zoología, Facultad Ciencias, UNAM. Apartado postal 70-399, 04510 México D.F., México.

²Amphibian and Diversity Research Center, University of Texas at Arlington. Arlington Texas 76019-0498, USA.

³Biology Department (Box 19498), University of Texas at Arlington, 501 South Nedderman Drive, 337 Life Science Building, Arlington, Texas 76019-049, USA.

*Correspondent: ofvq@servidor.unam.mx

Abstract. A hypothesis of historical area relationships for Mexico, Central, and South America was investigated by a cladistic biogeographic analysis using 10 taxon cladograms of the herpetofauna of Mexico. A hypothesis is presented based on previous narrative biogeographic scenarios and compared with the general area cladograms (GACs) obtained using reconciled trees of COMPONENT 2.0 and Brooks Parsimony Analysis (BPA). For tree reconciliation, 1 000 trees were saved after the analysis. BPA yielded 18 GACs (CI = 0.805, RI = 0.549). The GAC derived from tree reconciliation is more or less pectinate and has only 3 groups of 2 areas each. These groups consist of the Chihuahuan and Sonoran deserts as sister areas on the one hand (DCHI, DSON), and the Sierra Madre Oriental and Occidental as sister areas on the other (SMOR, SMOC). This latter clade is sister to the Chihuahuan and Sonoran desert clade. The third group has the Transvolcanic Belt and Sierra Madre del Sur as sister areas (TVA, SMEX). The GAC obtained by BPA showed 4 main groups of areas: the first is comprised of the Pacific coast of Mexico and the Balsas Depression (PCBAL), the Sierra Madre del Sur (SMEX), and the Transvolcanic Belt (TVA); the second group includes the Sierra Madre Oriental (SMOR), Sierra Madre Occidental (SMOC), Sonoran (DSON) and Chihuahuan deserts (DCHI); the third comprised the Highlands of Chiapas and Guatemala (CHIG), the Eastern Lowlands, on the Atlantic coast (ELL) and the Semiarid Lands of Tamaulipas-Texas (TAMS); the fourth group contains the Western Lowlands, in the Pacific coast (WLL) and northern South America (SA); the Talamanca Ridge (TALA) is isolated at the base of the 3 first groups. The GAC from narrative biogeography contains 3 groups: the first has areas of northern Mexico (DSON, DCHI, TAMPS), the second has areas from central Mexico (PCBAL, SMOR, SMOC, TVA), and third has areas from southern Mexico and Central America (SMEX, CHIG, TALA, WLL, ELL, SA). In general, the GAC from the BPA analysis shared more groups with the hypothesis of narrative biogeography; when compared to the GAC obtained via reconciled trees; however, all the GACs obtained are topologically distinct. Accounting for the lack of congruence between the narrative biogeography GAC, reconciled tree analysis and BPA, is challenging due to several factors: 1), erroneous interpretation of vicariant events when constructing the narrative area cladogram; 2), lack of congruence among patterns of speciation and endemism for the taxa used in this analysis; 3), the region under study is a geologically complex zone and the history of the inhabiting biota is equally complex; 4), there are many widespread species present in this region, and may obscure the relationship among the areas of endemism; 5), the patterns of endemism are poorly-defined and -studied in Mexico and Central America; 6), the incorrect selection of the areas of endemism used in this study. Despite these issues the results presented here are evidence of the multi-dimensional complexity of historical biogeographical processes in the region.

Key words: biogeography, Brooks Parsimony Analysis, reconciled trees, vicariance biogeography, dispersal.

Resumen. Se investigó una hipótesis de la relación histórica de las áreas para México, Centro y Sudamérica a partir de un análisis biogeográfico cladístico de 10 cladogramas taxonómicos de la herpetofauna de México. Se presentó y comparó una hipótesis narrativa con los cladogramas generales del área (GAC) obtenidos por los métodos de árboles reconciliados y Análisis de Parsimonia de Brooks (BPA). En el análisis de reconciliación de árboles se salvaron 1 000 cladogramas. Por otro lado, con el BPA se obtuvieron 18 GAC's (CI = 0.805, RI = 0.549). El GAC de la reconciliación de árboles es más bien pectinado y presenta sólo 3 grupos de 2 áreas cada uno; los desiertos de Sonora y Chihuahua (DSON, DCHI); las sierras Madre Oriental y Occidental (SMOR, SMOC) y a su vez éstas 2 como grupo hermano de las anteriores y el Eje Volcánico Transmexicano y la sierra Madre del Sur (TVA, SMEX). El GAC obtenido por BPA contiene 4 grupos principales de áreas: el primero abarca la costa del Pacífico de México y la depresión del Balsas (PCBAL), la sierra Madre del Sur (SMEX), y el Eje Volcánico Transmexicano (TVA); el segundo grupo incluye a la sierra Madre Oriental (SMOR),

la sierra Madre Occidental (SMOC), los desiertos de Sonora (DSON) y Chihuahua (DCHI); el tercero abarca las tierras altas de Chiapas y Guatemala (CHIG), las tierras bajas atlánticas del este (ELL) y las tierras semiáridas de Tamaulipas-Texas (TAMS); el cuarto incluye tierras bajas del Pacífico del oeste (WLL) y norte de Sudamérica (SA); la cordillera de Talamancas (TALA) está en la base de los primeros 3 grupos. El GAC de la biogeografía narrativa tiene 3 grupos; el primero tiene áreas del norte de México (DSON, DCHI, TAMPS), el segundo tiene áreas del centro de México (PCBAL, SMOR, SMOC, TVA), y el tercero del sur de México y Centroamérica (SMEX, CHIG, TALA, WLL, ELL, SA).

En general, el GAC derivado del BPA contiene grupos de áreas más parecidos con los de la hipótesis en la historia narrativa, si lo comparamos con el GAC obtenido por árboles reconciliados; sin embargo, todos los GAC's obtenidos son distintos en su topología. La carencia de congruencia entre los cladogramas de áreas derivados de la interpretación de la biogeografía narrativa y el de árboles reconciliados y del análisis de BPA se podría deber a varios factores: 1), interpretación errónea de los acontecimientos vicariantes al construir el cladograma de áreas de la biogeografía narrativa; 2), carencia de congruencia entre patrones de especiación y endemismo para las taxones empleados en este análisis; 3), la región bajo estudio es una zona geológica compleja y la historia de la biota es igualmente compleja; 4), hay muchas especies ampliamente distribuidas en la región, lo que puede oscurecer la relación entre las áreas de endemismos; 5), los patrones de endemismo están pobremente definidos y estudiados en México y Centroamérica; 6), selección incorrecta de las áreas de endemismo usadas en este estudio. Los resultados presentados aquí muestran la complejidad de la historia biogeográfica de la región.

Palabras clave: biogeografía, Análisis de Parsimonia de Brooks, árboles reconciliados, biogeografía de la vicarianza, dispersión.

Introduction

Several authors have attempted to explain the spatial and temporal origin of the Mexican herpetofauna. Gadow (1905) used geological evidence to explore the possible origin of the Mexican biota. As would be expected at that time, he suggested primarily dispersal hypotheses to explain these origins. However, his work has the value of being the first to try to explain the origin of the fauna of Mexico. Smith (1949) proposed that the Mexican herpetofauna originated with the arrival of 3 herpetofaunas previously identified by some authors for different taxa: Dunn (1931) and Schmidt (1943) for amphibians and reptiles, and Mayr (1946) for birds. These herpetofaunas are the Old Northern, the South American, and the North American.

Savage (1960) explained the origin of the herpetofauna of northern Mexico through its association with 3 Tertiary floras: a Neotropical herpetofauna associated with a Tertiary Neotropical Geoflora; old northern elements of the herpetofauna associated with an Arcto-Tertiary Geoflora, and young northern elements associated with a Madro-Tertiary Geoflora. Savage (1966) later proposed that there are 4 historic units of the Mesoamerican herpetofauna: a South American Element, an Old Northern Element, a Mesoamerican Element, and a Young Northern Element. Halffter (1964) gave a summary of the biogeographic works about Mexico's vertebrate fauna and compared their distribution with that of the entomofauna, from which he concluded that both faunas have different origins. More recently, Liebherr (1991) proposed a general area cladogram for the mountain regions of Mexico, based on the distribution of carabid beetles. Further Marshall

and Liebherr (2000) proposed a general area cladogram for all of Mexico using cladistic methods and different animal and plant taxa, the next year Flores-Villela and Goyenechea (2001), tested hypothesis of area cladograms based on similar patterns of areas of endemism as those used by Marshall and Liebherr (2000). Halas et al. (2005) using 9 geographical areas from Marshall and Liebherr (2000), analyzed the biogeographic relations introducing a taxon pulse approach to identify vicariant, dispersion, and extinction events that occurred within each of the areas analyzed. A similar approach was published by Brooks (2005), and proposing a new method to analyze area relationships, Phylogenetic Analysis for Comparing Tress (PACT), that has not been implemented. All of these 3 works employed different cladistics biogeographic methods to produce relationships of endemic areas in Mexico. A review of many of the different works dealing with the biogeography of Mexico was recently published by Morrone (2005). He reviews the different approaches to elucidate the complex biogeographic history of Mexico.

The works of Smith (1949) and Savage (1960, 1966) were based essentially on dispersal theories, since at the time that was the dominant paradigm. Savage (1982) updated his work on the origin of the Mesoamerican fauna considering the 4 biogeographic elements mentioned in his 1966 article. He postulated that the herpetofauna of Central America and parts of southern and southeastern Mexico were historically formed by 4 source units, which are:

- 1). An Old Northern Element. Examples of families belonging to this element include Rhinophrynidae, Xantusiidae, and Dermatemydidae.

- 2). A South American Element. Some genera

exemplifying this element are: *Leptodactylus*, *Physalaemus*, and some species of *Micrurus*.

3). A Mesoamerican Element. Examples of this element include: *Dermophis*, *Tomodactylus* (= *Eleutherodactylus*), *Ptychohyla*, *Basiliscus*, *Ungaliophis* and *Imantodes*.

4). A Young Tropical Element. Genera that exemplify this element include *Phrynosoma*, *Sceloporus* and *Cnemidophorus* (= *Aspidoscelis*).

Other components of Mexican herpetofauna are possibly associated with what Savage (1960) has called complexes, which he viewed as subdivisions of the Old Northern Element. They are Eastern American, Western American, and Southeastern American. Some examples of genera of the Ancient Northern Element are *Ambystoma*, *Acris*, and *Chrysemys* (see Morafka, 1977 for more details).

The main purpose of this paper is to present a hypothesis regarding the spatial and temporal origin of the Mexican and Central American herpetofauna based upon the narrative biogeography of various authors (Savage, 1982; Morafka, 1977), and to compare this hypothesis with others generated with cladistic methods using Brooks Parsimony Analysis (BPA) (Wiley, 1988; Brooks, 1990, Brooks et al., 2001) and tree reconciliation (Page, 1994). The PACT method proposed by Wojcicki and Brooks (2004) and Brooks (2005), contains algorithms still in development and is not considered in this analysis.

Materials and methods

We apply the criteria proposed by Savage (1960, 1966, and 1982) to delineate the historical herpetofaunal units, with some minor modifications.

Areas of Endemism: a hypothesis to explain the evolution of the areas of endemism in Mexico and Central America was generated, which is presented in the form of a general area cladogram (Fig. 1). This cladogram was constructed following the recommendation of Brooks (1990) and Brooks et al. (2001) that area cladograms be built considering the geological and ecological events that could have fragmented the fauna of a certain region (assuming the relative ages of the events are known). This hypothesis (Fig. 1) is proposed as a working scheme that will begin the process of ordering the facts and ideas related to the biogeographic history of Mexico. This hypothesis is based mainly upon the vicariance events proposed by Savage (1982) and Morafka (1977), reinterpretation of the general ideas of these authors with the evidence shown in other works, and with some of the cladistic analyses recently published (Marshall and Lieberr, 2000; Flores-Villela and Goyenechea, 2001). A first attempt to synthesize this

information can be found in Flores-Villela and Goyenechea (2001).

Thirteen areas of endemism were detected from the classic biogeography of Morafka (1977) and Savage (1982), identified in Flores-Villela (1991, 1993) and employed in Flores-Villela and Goyenechea (2001) (Fig. 2, details below).

Cladistic biogeographic methods (BPA, Tree reconciliation)

To test the validity of the narrative hypothesis, a tree reconciliation and a BPA were performed. The first analyses was done in COMPONENT 2.0 (Page, 1993), using Assumption 0 of Zandee and Roos (1987), one thousand general area cladograms were constructed (not shown).

In the BPA, the elements were coded in a data matrix and was analyzed using PAUP*, version 4.0b8 (Swofford, 2002), the missing areas were coded as "?" (Wiley, 1988; Brooks, 1990), and a hypothetical area (GE) coded all zeros was included to root the GAC (Brooks, 1981, 1990). Maximum parsimony (MP) analysis using a heuristic search option was performed considering character states as unordered and unweighted. A Nelson consensus was performed in both biogeographic analyses using COMPONENT 2.0 (Nelson, 1979; Flores-Villela and Goyenechea, 2001). The resulting general area cladograms (GAC's) were compared with the area cladogram derived from the narrative biogeography mentioned earlier (Fig. 1).

The origin of the Baja California fauna was not included in this analysis because it has been studied recently by Murphy (1983) and Grismer (2002), who used paleogeographic and genetic differentiation data. There is a recent study of the biogeography of Baja California with a slightly different approach Riddle et al. (2000) and Riddle and Hafner (2006).

Taxa Analyzed. The following taxonomic cladograms were used in the analysis: Hillis et al. (1983) for frogs of the *Rana pipiens* group; Hillis and de Sá (1988) for frogs of the *Rana palmipes* group; Zaldívar-Riverón et al. (2004) for coastal leopard frogs of the *Rana berlandieri* group; Savage (1987) for frogs of the *Craugastor gollmeri* group (although this group may be paraphyletic Crawford and Smith 2005); Campbell and Frost (1993) for lizards in the genus *Abronía* (family Anguillidae); Good (1988) for the lizard genus *Mesaspis*; Hodges and Zamudio (2004) for the lizard genus *Phrynosoma*; Crother et al. (1992) for the snake genus *Bothriechis*; Bryson et al. (2008) for the snake in the genus *Porthidium* group; Parra-Olea et al. (2005) for the salamander *Pseudoeurycea belli* species complex. From the works mentioned above, only those cladograms with no polytomies were used, with the exception of Zaldívar-

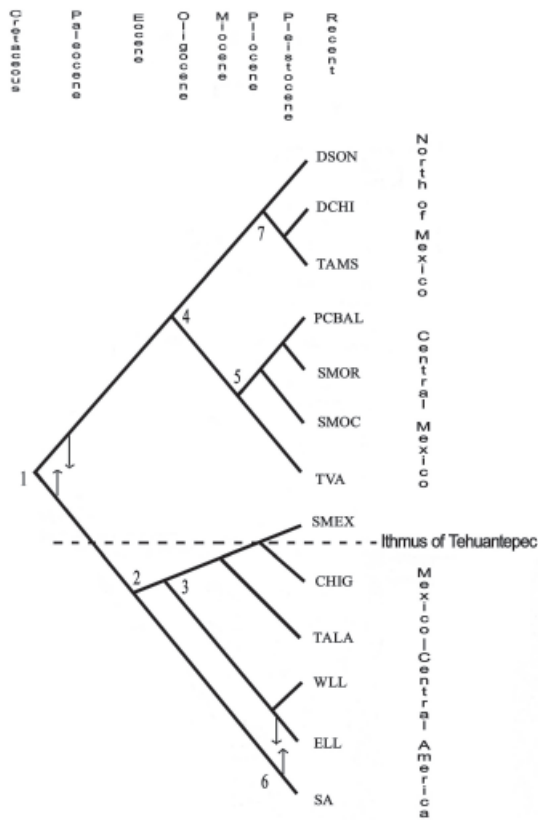

Figure 1. General area cladogram derived from the classic biogeography.

SA= Northern South America; ELL= Eastern Lowlands, in the Atlantic coast; WLL= Western Lowlands, in the Pacific coast; TALA= Talamanca ridge; CHIG= Highlands of Chiapas and Guatemala; SMEX= Highlands of Southern Mexico; TVA= Transvolcanic Belt; PCBAL= Pacific coast of Mexico and the Balsas Depression; SMOR= Sierra Madre Oriental; SMOC= Sierra Madre Occidental; DSON= Sonoran Desert and Southwestern United States; DCHI= Chihuahuan Desert and South-Central United States; TAMS= Semiarid lands of Tamaulipas-Texas and Southeastern United States.

1. Dispersion I of Savage (1982), SA+NA+MEX, Cretaceous-Paleocene. 2. Vicariance I of Savage (1982), Eocene. 3. Orogeny in Southern Mexico and Nuclear Central America that divides the highlands from the lowlands, TA+WLL+ELL, Oligocene-Miocene. 4. Increase of desertification and orogenic events, Vicariance II of Savage (1982), Oligocene-Miocene. The event of Dispersion II of Savage (1982) could be located between 2 and 4, although it is difficult to prove, see discussion. 5. Between the Miocene and Pliocene, several tectonic events originated the Sierra Madre Oriental and Sierra Madre Occidental. These changes affected the fragmentation of the ancestral Mojavian Desert and fragmented the biota of this region. Probably, these events isolated the lowlands of the Pacific coast and the Balsas depression. 6. Closing of the connection between Central and South America, Dispersion III of Savage (1982), Pliocene-Pleistocene. The arrows indicate dispersion events. The Isthmus of Tehuantepec has acted as an important barrier for the species from the highlands of southern Mexico, but has also been a

corridor for the species from the eastern and western lowlands. 7. With the formation of the Sierra Madre Occidental, the hypothetic barrier of San Gorgonio, and the expansion of the Gulf of California, the Sonoran desert differentiates from the other North American deserts, end of Pliocene. Although, the semiarid lands of Tamaulipas-Texas had been differentiated since the Miocene, according to Morafka (1977), there was interchange with the Chihuahuan desert until the Pleistocene.



Figure 2. Areas of endemism in Mexico and Central America: 1), north of South America (SA); 2), eastern lowlands, in the Atlantic coast (ELL); 3), western lowlands, in the Pacific coast (WLL); 4), Talamanca ridge (TALA); 5), highlands of Chiapas and Guatemala (CHIG); 6), highlands of southern Mexico (SMEX); 7), Transvolcanic Belt (TVA); 8), Pacific coast of Mexico and the Balsas depression (PCBAL); 9), Sierra Madre Oriental (SMOR); 10), Sierra Madre Occidental (SMOC); 11), Sonoran desert and southwestern United States (DSON); 12), Chihuahuan desert and south-central United States (DCHI), and 13), semiarid land of Tamaulipas-Texas and southeastern United States (TAMS).

Riverón et al. (2004) and Parra-Olea et al. (2005). The area cladograms of the 10 original groups that were used for the analysis are shown in Figure 3.

Results

Historic explanation of the origin of the herpetofauna.

Despite the fact that Savage (1982) has explained the origin of the Mesoamerican herpetofauna in a modern biogeographic framework, his statements are mostly predictions about area relationships based on distributions and geology (see Crother et al., 1992). More rigorous cladistic methods are needed in order to examine Savage’s (1982) theory and test its validity (Cadle, 1985). Despite

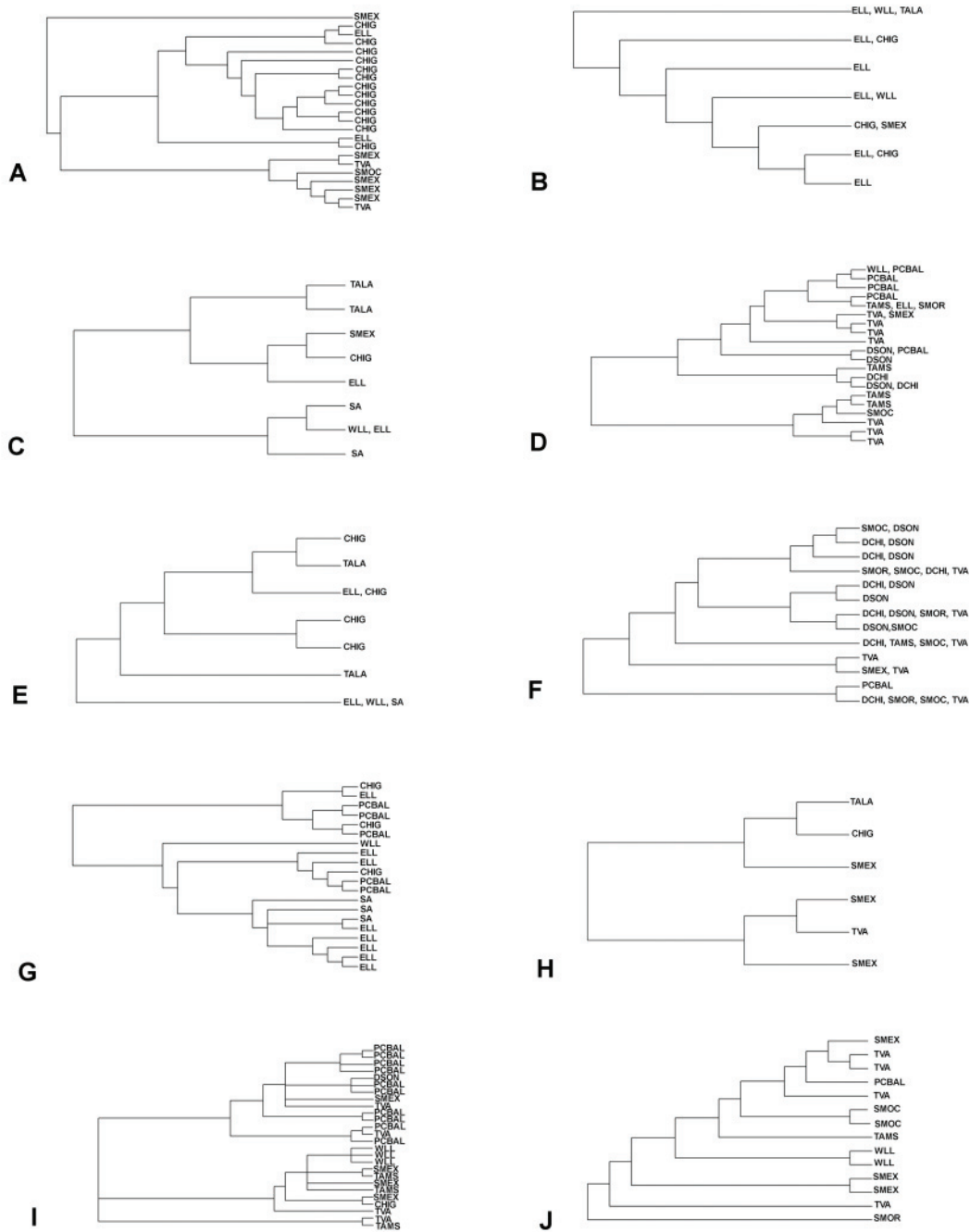

Figure 3. Original area cladograms of the 10 taxa used in the biogeographic analysis. The taxa have been substituted by the areas of endemism they inhabit, considering Figure 2: A), *Abronia* (Campbell and Frost, 1993); B), *Eleutherodactylus gollmeri* group (Savage, 1987); C), *Rana palmipes* group (Hillis and De Sá, 1988); D), *Rana pipiens* group (Hillis et al., 1983); E), *Bothriechis* (Crother et al., 1992); F), *Phrynosoma* (Hodges and Zamudio, 2004); G), *Porthidium* group (Bryson et al., 2008); H), *Rana berlandieri* group (Zaldívar-Riverón et al., 2004); I), *Mesaspis* (Good, 1988), and J), for *Pseudoeurycea belli* species complex (Parra-Olea et al., 2005).

advances in the use of cladistic methods in biogeography, knowledge of the origin of the herpetofauna of Mexico is still in an essentially classic (narrative) state, except for the work of Flores-Villela and Goyenechea (2001).

It is well known that the formation of the Central American isthmus influenced the history of the Mexican biota (Rosen, 1978; Savage, 1982). Climatic and vegetation changes of the last several thousand years have also had some impact on the history of the Mexican biota (Duellman, 1960, 1966; Axelrod, 1975; Johnson, 1989; for a synthesis see Toledo, 1982). Savage (1982) proposed a sequence of events to explain the origin of the Mesoamerican herpetofauna, partially based on the geological model proposed by Rosen (1976). This sequence offers a similar explanation to that of Duellman (1970) for the origin of hylid frogs in Mexico and Central America. In 1985, Rosen reviewed several geological theories about the origin of the Central American region and concluded that there are 2 groups of theories which, although contradictory in some of their principles, offer similar accounts of the terrestrial connections between North and South America and the terrestrial discontinuities between these 2 land masses. The geological theories reviewed by Rosen (1985) do not contradict the model that he previously proposed (Rosen 1976) or Savage (1982).

The history of the distribution of the fauna since the end of the Pliocene and the Pleistocene has been strongly influenced by climatic and vegetation changes (Savage, 1982). Although most of the recent amphibian and reptile groups were already present in the North American region, Mexico, and Central America, their distributions changed because of climatic and vegetation changes.

As Toledo (1982) suggested from the Pleistocene refugia perspective, the climatic fluctuations during that period most likely affected the vegetation of the lowlands in the following 3 ways: 1), during cold and dry cycles, lowland vegetation was dominated by pine and oak forests; 2), during cold and wet cycles, communities of cloud and oak forests were established, and 3), during hot and dry cycles, deciduous and semi-deciduous forests possibly dominated.

The highlands of central Mexico have a mosaic of faunas with different biogeographic histories (Savage, 1982). These lands have been isolated from the central plateau and southern United States as a consequence of increased aridity and low temperatures from at least the middle Tertiary (Axelrod, 1975; Morafka, 1977; Rosen, 1978). It is possible that the climatic fluctuations led to numerous extinction and isolation events, as in the turtles of the genera *Terrapene* and *Chelydra* (Milstead, 1967; Van Devender and Tessman, 1975). Morafka (1977) supported this line of evidence. He mentioned that several ancient

tropical elements became extinct, resulting in the modern North American herpetofauna. The extinction events may have been responsible for the paucity of endemics and the disjunct distributions of several taxa in northeastern Mexico (Savage, 1982). It is very likely that the few endemics in this region are paleoendemics like *Apalone*, *Coleonyx* and, probably, *Gopherus* and *Uma*. The species of *Gopherus* and *Uma* in northern Mexico and the southern United States have been isolated from one another for about 5 million years, beginning in the middle Pliocene (Lamb et al., 1989; Adest, 1977, respectively). This is coincident with increasing aridity in that area. There is no agreement among authors that increasing aridity caused the isolation of the species of the genus *Gopherus* (see Lamb et al., 1989). The 3 subspecies of painted turtles (*Trachemys scripta*) of northern Mexico are more closely related to each other than to other subspecies of this complex and have apparently evolved in isolation in the Chihuahuan desert (Legler, 1990). Morafka (1977) has pointed out that the Chihuahuan desert, particularly the Mapimi subprovince, is rich in paleoendemics. The present distribution of many groups supports the north-south vicariance (between northern Mexico-southern United States and the low and highland vicariance of central Mexico); for example, the frogs of the *Rana pipiens* complex (Hillis et al., 1983), salamanders of the family Plethodontidae (Wake and Lynch, 1976; Hendrickson, 1986; Wake, 1987), genera of the xantusids, *Xantusia* and *Klauberina* in the north and *Lepidophyma* in the south (Crother et al., 1986; Sites et al., 1986; Bezy and Sites, 1987); species of *Phrynosoma* (Montanucci, 1987), and the separation of the species of *Elgaria* (Good, 1988; Grismer, 1988). Martin and Harrel (1957) show evidence of the north-south vicariance of the biota of Mexican montane zones.

The southern Mexican highlands were isolated by the formation of the Isthmus of Tehuantepec; this seems to have acted as a barrier and corridor at different times during the Cenozoic (Duellman, 1960, 1966; Savage, 1966; Stuart, 1966; Halffter, 1978; Reyes Castillo and Halffter, 1978; Campbell, 1984). The isolation of the southern Mexican highlands is evident through several faunistic discontinuities noticed in different groups of organisms in these highlands and those of Central America. Among other examples, some elements of the herpetofauna can be cited (Duellman, 1966; Savage, 1982; Campbell, 1984), particularly the frogs of the *Rana palmipes* complex (Hillis and de Sa, 1988), the frogs of the family Hylidae (Duellman, 1970), the salamanders of the Bolitoglossini tribe (Wake, 1987 and references therein), the lizard genera *Abronia* and *Mesaspis* (Good, 1988), and of the genus *Lepidophyma* (see Sites et al., 1986 and Bezy and Sites, 1987), and also some groups of insects (Reyes

Castillo and Halffter, 1978; Halffter, 1987). The genera *Ophryacus* and *Bothriechis* also exemplify the isolation of the southern Mexican highlands (Werman, 1992; Crother et al., 1992).

The geographical isolation of the highlands of Mexico (Transvolcanic Belt, Sierra Madre del Sur, and the highlands of Chiapas-Guatemala) and the climatic fluctuations of the Pleistocene allowed the evolution of faunistic elements *in situ*, producing numerous allopatric and parapatric present-day distributions, probably as a result of vicariance events occurring in the ancestral populations (for a well documented example, with genetic and geologic evidence, see Wake and Lynch, 1982, in the section called Nuclear Central America, and Johnson, 1990, Crother et al., 1992). These distributional patterns can be traced in a substantial portion of the taxa present in this area, which also show several endemic species with limited distribution; species of the genera, the former *Hyla*, *Craugastor*, *Rana*, *Pseudoeurycea*, *Chiropterotriton*, *Abronia*, *Adelphicos*, *Bothriechis*, *Geophis*, *Rhadinaea* and *Tantilla*, are among the most conspicuous endemics. This observation has been supported by Wake (1987) in his study of the salamander of the family Plethodontidae. Ramamoorthy and Lorence (1987) discussed this same allopatric event in relation to several species of plants in central Mexico. Crother et al. (1992) show the same for *Bothriechis*; Reyes Castillo and Halffter (1978) and Reyes Castillo (1982) show evidence of the same allopatric event when discussing the distribution of the pasalid beetles; the same can be said for Kohlmann and Halffter (1988) in their review of the distribution of the genus *Ateuchus* of the family Scarabaeidae; and Halffter (1987) in his review of the distribution of the entomofauna in general. Shaffer (1984) mentions that the genera of salamanders *Ambystoma* and *Rhiacosiredon* (now *Ambystoma*) evolved in isolation from northern species on the Transvolcanic Belt in the last 10 to 12 million years ago. He states that when the Transvolcanic Belt was formed, many of the species were already isolated; although he asserts that it is possible that the isolation could have occurred later, during the Pliocene-Pleistocene.

Undoubtedly there have been other vicariance events of lesser magnitude in the highlands of Mexico, as Good (1988) and Johnson (1989, 1990) have proposed. Nevertheless, these are difficult to detect because we lack detailed cladistic studies about many taxa inhabiting this zone. Johnson (1989, 1990) adds that post-Pliocene vicariance events could have occurred, but did not promote or result in speciation events.

In summary, it seems that the highland herpetofaunas show a high proportion of endemics, restricted to small geographic areas, in contrast with the humid, tropical

forests of the eastern lowlands (Duellman, 1966). Savage (1982) stated that the southern highlands of Mexico and Guatemala, compared with the rest of Central America, do not have many species in common, but they certainly share many endemics. In Omiltemi, state of Guerrero, for example, 13 of 37 herpetological taxa recorded for the area, are endemic (35.1%) (Flores-Villela and Muñoz-Alonso, 1993) most of which are associated with pine and cloud forests. Meanwhile, 19 of 149 taxa (12.7%) recorded in the region of Los Tuxtlas, Veracruz, are endemic (Pérez-Higareda et al., 1987). Some endemic species from Los Tuxtlas are associated with cloud forest, for example 2 species of *Abronia*, *Pseudoeurycea werleri*, and others (Pelcastre-Villafuerte and Flores-Villela, 1992). In contrast, Duellman (1966) showed that the herpetofauna from the humid Mesoamerican lowlands does not show great dissimilarities but, instead, the species have a more or less continuous distribution. For example, of the 149 species of amphibians and reptiles that occur in Los Tuxtlas, at least 117 have a distribution that goes beyond the region, spreading in many cases as far as Central America or some other region in Mexico (Pérez-Higareda, et al., 1987). It is possible that the cloud, pine, and oak forests in the Los Tuxtlas region may have originated recently. They may have become isolated in the higher elevations of Los Tuxtlas during the last 40 000 years when the massif was already formed. The existing relations between some elements of this fauna and the highlands in the extreme east of Oaxaca can be explained by dispersions during times of cold and wet climate. Later, the fauna in both places became isolated, leading to allopatric speciation. The species of the genus *Abronia* in Los Tuxtlas, whose closest congeners are found in the highlands of Oaxaca, may display this distribution (for more details see Campbell, 1984). Wendt (1989) mentions some similar data in his study of the flora from Los Chimalapas.

The origin of the Pacific lowlands is more difficult to explain (Toledo, 1982). Although the herpetofauna of this area and that of the coastal plain of the Gulf of Mexico are more or less continuous, the Pacific lowlands contain more endemic species. There are also significant differences in climate and vegetation types compared to the eastern lowlands (Savage, 1982). Some of the most characteristic elements of the Pacific are the genera *Syrrhophus*, *Bipes*, some species of *Phyllodactylus* and several species of *Anolis*. Generally, these groups of species exhibit allopatric or parapatric distributions along the Pacific coast, possibly as a result of climatic fluctuations. A similar phenomenon has been observed by Toledo-Manzur (1982) in the plant genus *Bursera*. He noted that vicariance phenomena may have possibly occurred in the eastern and western depression of the Balsas basin, separating species of

Bursera that now inhabit those regions.

We have generated a working hypothesis based on 3 different sources; the ideas initiated by Savage (1982), the most recent cladistic studies, and the comparison of the areas of distribution of the Mexican herpetofauna. This hypothesis is presented as a general area cladogram (Fig. 1). This hypothesis considers 3 important elements: 1), the relative time scale in which the geological and/or ecological events that led to vicariance or dispersion hypothetically took place; 2), the foremost geographic zones (or areas of endemism) in which the dispersion and/or vicariance events probably occurred, and 3), the historical geographic elements. Within the area cladogram, the barrier of the Isthmus of Tehuantepec divides the land to the east and west respectively.

Areas of endemism in Mexico and Central America and biogeographical methods.

Thirteen areas of endemism (Fig. 2) were detected from the classic biogeography of Morafka (1977) and Savage (1982) and taking into account collateral evidences from other publications already mentioned. These areas are shown in Figure 2, the WLL and PCBAL areas have been considered separately because the southern distributions of many species from the Pacific coast that occur in PCBAL do not extend beyond the Isthmus of Tehuantepec. In contrast, the distribution of many species of the coastal plain of the Gulf of Mexico goes from the north of the state of Veracruz as far as Central America.

The GAC from the Nelson consensus form the reconciled tree is presented in Figure 4. The GAC shows 2 very delimited groups, in which the first group includes (PCBAL(TAMS(CHIG((SMOR + SMOC)+(DSON + DCHI)))))) and the second group includes (TVA + SMEX). These 2 groups are sisters, and all of the other areas (WLL, ELL, TALA, and SA) are paraphyletic in respect to them.

Analysis of the primary BPA data matrix (13 areas x 326 elements, data matrix are shown in Fig. 5), produced 18 equally parsimonious trees (length= 405, CI= 0.805, RI= 0.549, RC= 0.442) (Fig. 6). A Nelson consensus was performed with the resulting GACs of BPA analysis using COMPONENT 2.0 (Page, 1993) (Fig. 7). This GAC has 5 groups; the first include to (PCBAL(SMEX + TVA)), is sister of the second group which includes (SMOR(SMOC(DSON + DCHI))); the third group is a polytomy that contains CHIG, ELL, TAMS, and it is sister to the 2 mentioned above; the fourth group corresponds with TALA and finally, the group that is sister of all includes to (WLL + SA).

The resulting GACs are topologically distinct, although they have many elements in common (Figs. 1, 4 and 7). The relationship between the DSON + DCHI; SMOR +

SMOC; also the SMEX + TVA are evident, they have a shared historical association in the BPA and reconciled trees analysis (Figs. 4 and 7).

The 3 GACs differ principally in the position of the CHIG, the PCBAL, TAMS and ELL.

Discussion

The history of the fauna of Mexico and Central America is complex (e.g. Marshall and Lieberr, 2000; Flores-Villela and Goyenechea, 2001; Halas et al. 2005; Morrone, 2005). The herpetofauna is composed of faunas with different biogeographical affinities (North American, South American, and autochthonous); the area has experienced multiple and complex geological events (the origin of the Antilles, the orogenies of the middle Cenozoic, the glaciation effects), and there has been dispersal of biotas through Central America.

It appears that, biogeographically, Mexico and Central America are hybrid zones, so it is no easy task to find a coherent pattern for the history of their biota (e.g. Croizat, 1958 identified the Mesoamerican region as a complex biogeographic zone, because several generalized tracks cross in this part of the continent). This may be the reason why many investigators, when trying to explain the origin of the Mesoamerican fauna, proposed different histories for each group. Even though the Mexico-Central America zone is biogeographically complex, the general patterns of the evolution of its biota must obey certain coherent features of mixed biogeographic history.

Numerous authors have attempted to explain the origin of the fauna of Mexico and Central America. Perhaps the most complete works are those of Savage (1966, 1974, 1982). Savage (1982) explains that there are 4 historical sources for the Mesoamerican herpetofauna: a South American element, an Old Northern element, a Middle American element, and a Young Northern element. Interestingly, these elements are equivalent to those proposed by Halffter (1961, 1964, 1976, 1978) for insects, and by Delgadillo (1979, 1986) for mosses. The fact that biogeographic patterns of these 3 groups of organisms are recognized as equivalent by different authors, either as dispersion units or constituting elements of the fauna, suggests that shared biogeographic histories exist despite different affinities (Table 1). Although it has been pointed out that the biogeographic histories are different for each group (Halffter, 1964, 1976; Noonan, 1988), these differences are probably more superficial than real. This is because the conception of the different dispersion patterns are based on *ad hoc* assumptions, and have been postulated partially by intuitive methods which are not easily tested.

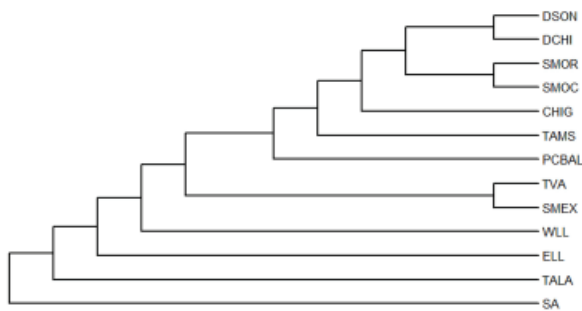

Figure 4. General area cladogram derived from reconciled trees (Nelson consensus), considering the 10 taxa in Figure 3. The areas of endemism are the same as those in Figure 2.

Halffter (1978) recognized the similarity of his results to those observed by other herpetologists when he proposed the Montane Mesoamerican dispersion pattern.

An analysis of the different patterns (or elements) proposed by Savage (1966, 1982), Halffter (1961, 1964, 1976, 1978) and Delgadillo (1979, 1986), reveals that they have 2 patterns in common, a South American and a Mesoamerican. These biogeographic patterns are not equivalent to those proposed by Savage (1974) for mammals of the region. At least, the presence of the Mesoamerican pattern indicates the existence of an autochthonous biota of relatively recent origin. The existence of a South American pattern suggests that there was contact between North and South America at some time that resulted in a dispersion event of the biota. Another faunistic element is common to both the herpetofauna and entomofauna: the Old Northern (herpetofauna) and the Paleoamerican (entomofauna). This historic element of the Mexican biota has many affinities with the North American fauna. This is an autochthonous element of the Mexican fauna of ancient origin, despite other authors' interpretations (e.g. Savage, 1966, 1982), who suggested it arrived to Mexico by dispersion. The emphasis on the dispersion events proposed in the literature force us to suppose that Mexico was practically an empty box (see more details in Brooks, 2005; Morrone, 2005; Contreras et al., 2007; and Luna-Vega, 2008), and has been getting its flora and fauna from the different waves of faunistic and floristic invasions. It is because of this that the Mexican biota has been conceived of as a mixture of different elements without considering the existence of a high percentage of autochthonous groups, which have evolved and diversified in the country (see comments in Halffter, 1978; Savage, 1982; Delgadillo, 1986; Escalante-Pliego et al., 1993).

It is evident that the origin of the Mexican fauna has been influenced by dispersion as well as vicariance events, as Savage (1982), Flores-Villela and Goyenechea (2001),

	0	5	10	15	20	25	30	35	40	45	50	55	60	65	70
GE	0	0	0	0	0	0	0	0	0	0	0	0	0	0	0
SMEX	1	1	1	1	1	1	1	1	1	1	1	1	1	1	1
CHIG	1	1	1	1	1	1	1	1	1	1	1	1	1	1	1
ELL	1	1	1	1	1	1	1	1	1	1	1	1	1	1	1
TVA	1	1	1	1	1	1	1	1	1	1	1	1	1	1	1
SMOC	1	1	1	1	1	1	1	1	1	1	1	1	1	1	1
WLL	1	1	1	1	1	1	1	1	1	1	1	1	1	1	1
TALA	1	1	1	1	1	1	1	1	1	1	1	1	1	1	1
SA	1	1	1	1	1	1	1	1	1	1	1	1	1	1	1
PCBAL	1	1	1	1	1	1	1	1	1	1	1	1	1	1	1
TAMS	1	1	1	1	1	1	1	1	1	1	1	1	1	1	1
SMOR	1	1	1	1	1	1	1	1	1	1	1	1	1	1	1
DSON	1	1	1	1	1	1	1	1	1	1	1	1	1	1	1
DCHI	1	1	1	1	1	1	1	1	1	1	1	1	1	1	1

Figure 5. BPA matrix listing the geographical distributions and binary codes for 10 area cladograms of the taxa used in the biogeographic analysis.

Brooks (2005) and Halas et al. (2005) attest. However, the dispersion events that have been involved in the formation of the Mexican fauna have not been isolated, as has been proposed by dispersalists hypotheses. Dispersions have occurred in many, not few isolated groups. Selected groups of mammals, birds, amphibians, reptiles, insects, plants, among others, have moved to the north as well as to the south, crossing Central America at different times. These movements most likely occurred as a single collective biota, not as isolated events (see Halffter, 1961, 1964,

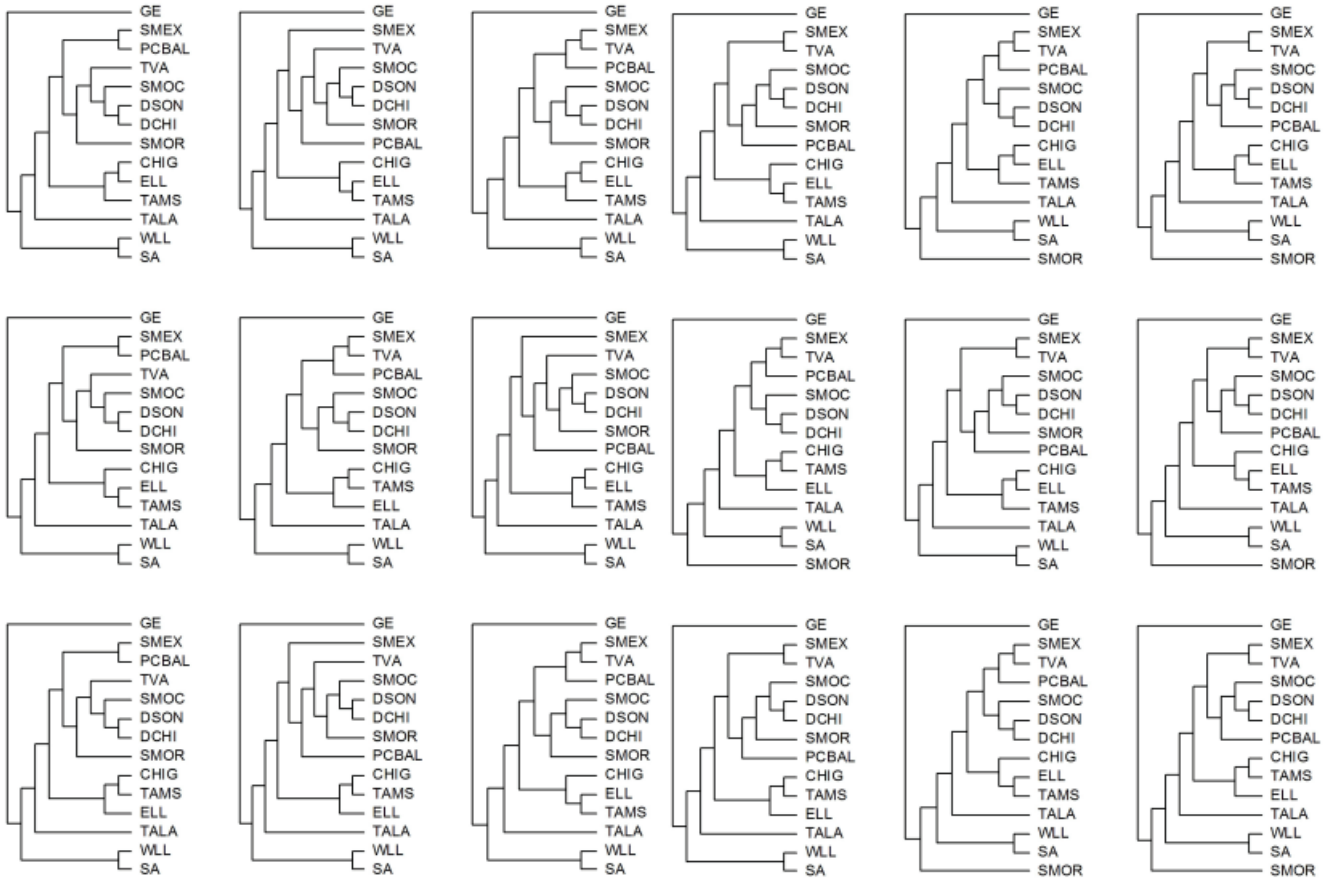

Figure 6. General area cladograms derived from the BPA, considering the 10 taxa in Figure 3. The areas of endemism are the same as those in Figure 2.

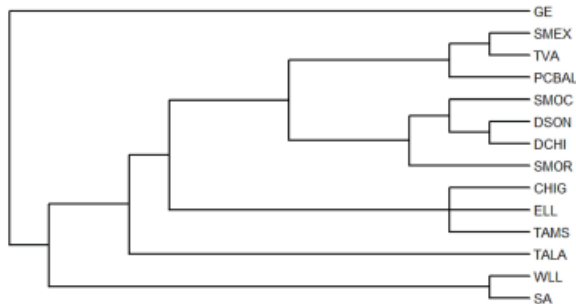

Figure 7. General area cladogram derived from BPA analysis (Nelson consensus), considering the 10 taxa in the Figure 3. The areas of endemism are the same as those in Figure 2.

1976, 1978 for insects; Savage, 1966, 1982 for amphibians and reptiles; Savage, 1974 and Webb, 1977 for mammals; Gentry, 1982 for angiosperms; Hanken and Wake, 1982 for salamanders; Delgadillo, 1986 for mosses). The magnitude of these dispersal waves could have been different for

each group depending on the vagility and ecological conditions at the moment they occurred. Interactions with other existing groups, such as competition and predation probably also influenced these migrations.

Vicariance events have equally affected the autochthonous groups and those that arrived by dispersion (before the vicariant event). Therefore, both faunistic groups have been recently influenced by similar biogeographic histories. However, vicariance events can be easily obscured by extinction events, even in those groups that migrated from different places. Vicariance and concordant dispersion events are rarely discrete in geological time (Cadle, 1985).

Another important controversy concerning the biogeographic history of Mexico and South America is the effect of the climatic and vegetational changes resulting from the Pleistocene glaciations. The present work indirectly proposes that Pleistocene climatic changes may have caused Mexican regions of high endemism (Transvolcanic Belt, Sierra Madre del Sur, and Pacific coast)

Table 1. Historical elements of the Mexican biota based on Savage (1982), Halffter (1961, 1964, 1976, 1978) and Delgadillo (1979, 1986) (see text for more details)

<i>Savage</i> <i>Herpetofauna</i>	<i>Halffter</i> <i>Entomofauna</i>	<i>Delgadillo</i> <i>Mosses</i>
South American	Mexican platau	Mexico-N of South America
	Neotropical	Mexico-N of South America
	Typical	Antillean
Old Northern	PaleoAmerican	
Young Northern	Neartic	
Mesoamerican	Mountain Mesoamerican	Mesoamerican

to experience local vicariance events that influenced the diversity of the inhabiting biota (Duellman, 1960; Myers, 1974; Lee, 1980). It is possible that the cloud forests (in the Transvolcanic Belt and the Sierra Madre del Sur) and the deciduous forests (in the Pacific coast) are currently acting as refuge zones, in the same way that the humid forests did during the glaciation periods. This could be applied to Mexico and Central America because the cloud forests (Llorente, 1983) and the deciduous forests of the Pacific coast (Toledo, 1982) have high rates of endemism. The cloud forest has more endemic species than any other habitat in Mexico and Central America (Lewis, 1971 and citations therein; Wake and Lynch, 1976 for plethodontids; Flores-Villela and Gerez, 1994, who give data for Mexico on the vertebrate richness for all vegetation's types). The Pacific deciduous forests have the third highest level of Mexican vertebrate endemics, after oak forest and arid tropical scrub forest (Flores-Villela and Gerez, 1994). In contrast, the endemic herpetofauna inhabiting the arid tropical scrub forest of northern Mexico, and southern United States seems to be a relict with paleoendemic species, which have survived the xeric conditions and temperature fluctuations of the last few million years.

At present, controversy exists about the validity of the model of Pleistocene refugia as explanation of the biological richness of the Neotropical humid forests (Cracraft and Purnell, 1988; De Souza, 1991; Colinvaux et al., 2000; Willis and Whittaker, 2000; Knapp and Mallet, 2003). This model is not very applicable to the humid forests of Mexico and Central America, since this forest has only recently become established in this region. Nevertheless, the vicariance model offered by climatic changes of the Pleistocene may explain the high number of endemics in the cloud and deciduous forests in an inverse fashion; that is, at present, the cloud and deciduous forests may serve as refuges for a biota that used to occupy larger

and more continuous areas (Rzedowski and McVaugh, 1966 recognized that the cloud forests in Mexico represent only a fragment of a vegetation that was more extensive in the past). However, this latter interpretation of the phenomenon considers that speciation events are recent, no older than the Pleistocene. The available evidence suggests that speciation events in some groups occurred during the Pleistocene (e.g. butterflies; Brown, 1987), but for other groups like leptodactylids, the events are pre-Pleistocene as well as Pleistocene (Lynch, 1988). Cracraft and Plum (1988) offered an extensive discussion regarding this subject. Referring to the speciation patterns of birds in South America, these authors explain that "The refuge hypothesis remains a viable explanation for the vicariance patterns documented in this paper, but considerable problems exist with the method by which this model (pleistocenic refuges) is often applied", parentheses of the authors.

Continuous orogenic processes offer another explanation for the high occurrence of allopatric species in areas of endemism in Mexico and Central America. Supporting evidence for the latter can be found in the work of Wake and Lynch (1982) for the salamanders of the *Bolitoglossa franklini* group, from Nuclear Central America. Campbell (1984) offers a general discussion of this issue for the southern highlands of Mexico and Crother et al. (1992) for vipers of the genus *Bothriechis*.

It is possible that some other vicariance events of lesser strength have occurred in the highlands of Mexico, as has been proposed by Good (1988) and Johnson (1989, 1990). However, these events are difficult to detect because we lack detailed geological information and an understanding of the cladistic relationships of many taxa that inhabit the region. As discussed above, Johnson (1989, 1990) suggests that post-Pliocene vicariance events could have occurred, but those did not promote many speciation events. This supports the idea that speciation events occurred earlier than the climatic changes of the Pleistocene. It also supports the idea that vegetation changes of the Mexican lowlands, which occurred at the same time as the climatic and temperature fluctuations, may not have significantly affected the origin of the Mexican and Central American faunas. However, they could have affected the distributional ranges of many species.

The area cladogram in Figure 1 represents an attempt to organize the hypothetical vicariance events that promoted differentiation of the Mexican and Central American biotas proposed by Savage (1982). Nevertheless this cladogram does not have much agreement with those in Figures 4 (reconciled trees) or 7 (BPA analysis). The cladograms in Figures 4 and 7 show that the Sonoran and Chihuahuan deserts have shared a common history. This

relationship agrees with the relationship predicted by narrative biogeography (Fig. 1). However, the relationship (TAMPS(DSON,DCHI)) shown in Figure 1 is not supported by BPA cladogram or reconciled trees (Figs. 4 and 7, respectively). This is probably due to the fact that Tamaulipas-Texas is of more recent origin than the Sonoran and Chihuahuan deserts, and may have incorporated more fauna from the humid tropics in later times (see Flores-Villela and Goyenechea, 2001). Though a relationship between the Sonoran and Chihuahuan deserts with the Tamaulipas-Texas region was proposed by Riddle and Honeycutt (1990), based on a study of rodents of the genus *Onychomys*, and by Morrone et al. (1999) on insects, our results do not recover this relationship.

The close relationship between the highlands of central Mexico and the highlands of Nuclear Central America is highly concordant with narrative biogeography, because of the origin and evolution of the Mesoamerican fauna in the latter region. For example, Wake and Lynch (1976) and Wake (1987) point out that 3 great diversification centers exist for the salamanders of the family Plethodontidae: 1), the Transvolcanic Belt and the highlands of northern Oaxaca; 2), Nuclear Central America, and 3), the Talamancan Mountains. These regions are part of the endemic regions of Mexico and Central America, as considered in this study. Reyes Castillo and Halffter (1978) and Halffter (1987) showed similar evidence for the distribution of the insects belonging to the Mesoamerican pattern sensu Halffter, (1978).

Delgadillo (1987) mentions that a great number of endemic mosses exist in the Transvolcanic Belt, and Cadle (1985) offers similar data, referring to the snakes of the subfamily Xenodontinae from the eastern part of the Transvolcanic Belt. A close relationship between the areas of central Mexico (Sierra Madre del Sur, Transvolcanic Belt), and the highlands of Central America (highlands of Chiapas-Guatemala, Talamancan Mountains), was also found in 2 independent analyses with BPA (Marshall and Liebherr, 2000) and with reconciled trees (Flores-Villela and Goyenechea, 2001).

The ambiguous relationship of northern South America with the rest of the areas of endemism is probably an issue having to do with our taxonomic sampling. The taxa used in the BPA are widely distributed in the eastern and western low and middle elevations, from southern Mexico to South America, for example species of the *Rana palmipes* group, species of the *Craugastor gollmeri* group, snakes of the genera *Bothriechis* and *Porthidium*.

The lack of absolute congruence between the area cladogram derived from the interpretation of the narrative biogeography and those from the reconciled and BPA analyses could be accounted by several factors:

1. Erroneous interpretation of the vicariant events when constructing the area cladogram of Figure 1.

2. The lack of congruence among patterns of speciation and endemism for the taxa used in this analysis, is due to different historic frames, and have responded differently to vicariant events (discussed below).

3. The region under study is a geologically complex zone. Therefore, the history of the inhabiting biota is equally complex (see Flores-Villela and Goyenechea, 2001; Marshall and Liebherr, 2000; Brooks, 2005; Halas et al. 2005).

4. There have been at least 2 important dispersion events of the biota in the area of study, and there are many widespread species present in this region. These taxa of wide distribution may obscure the relationship among the areas of endemism. Additionally, Flores-Villela and Goyenechea (2001) demonstrated that, in particular, the lowlands of the Pacific coast and Gulf of Mexico have several taxa that may have gotten there by dispersal events. Brooks (2005) proposed 3 main dispersal events, involving mainly dispersal from highlands to highlands. We consider these more unlikely since there are natural barriers that make these events more improbable.

5. The patterns of endemism are poorly defined and studied in Mexico and Central America. In contrast, Cracraft (1986) found high congruence among areas of endemism for the Australian bird fauna. This contrasts with findings in Mexico and Central America, where similarly clear patterns of overlap in areas of endemism between taxa are not nearly so striking. It may simply be that the patterns of endemism in Australia are well studied and understood because Australia does not have the geological complexity of Mexico and Central America. In Mexico, in recent years numerous studies to identify areas of endemism have been carried out using parsimony analysis of endemism (see Morrone, 2005), and there is no consensus on a general pattern of endemic areas.

6. The incorrect selection of the areas of endemism used in this study, or maybe the possible subdivision or fusion of some of them in to smaller areas, will show more accurately the historic relation among them. For example, Marshall and Liebherr (2000) mixed highlands and lowlands in the Pacific coast, the Gulf of Mexico and Central America; areas that are considered to be different in this analysis and in that of Flores-Villela and Goyenechea (2001).

For Holarctic amphibians, low congruence has been found among species that show similar patterns of distribution (Sage et al., 1982). There are similar problems of lack of congruence in the patterns of distribution for the insects of North America. Noonan (1988) showed that there is lack of total congruence among the distribution

of the insect fauna of North America and Mexico, due to several factors that obscure the general patterns, such as: 1), dispersal through barriers; 2), dispersion or cyclical vicariance, due to the formation and disappearance of barriers; 3), drastic changes in areas of distribution during the Pleistocene and other epochs, and 4), extinction of some taxa. This author also explains that more evidence must be sought using other groups to validate or refute his results.

The North American deserts illustrate the complexity of the problem. According to Morafka (1977), the herpetofauna from the Chihuahuan and Sonoran deserts are not closely related. There is evidence derived from the analysis of mitochondrial DNA (Lamb et al., 1989) from the turtle species of the deserts of northern Mexico and the southwestern United States which show that the species from the Sonoran desert are more closely related with the semiarid lands of Tamaulipas-Texas, and the species from the Chihuahuan desert with those from the Florida Peninsula. Nonetheless, the data from the abovementioned study were analyzed with phenetic and not phylogenetic methods. Additionally, this study contradicts our findings regarding the relationships of the Sonoran and Chihuahuan deserts and the findings of Marshall and Lieberr (2000) and those of Flores-Villela and Goyenechea (2001). Other studies with individual taxa have shown a similar relation between the Sonoran and Chihuahuan deserts as well (Devitt, 2006; Riddle and Hafner, 2006, Leaché and Mulcahy, 2007).

The results of the present study are limited in finding congruent relationships for several of the areas of endemism studied. Considering that the area under study may be a hybrid zone, because it is inhabited by biotas with different biogeographic affinities, a serious objection could be raised to the results presented in this work. Nevertheless, to date, there is no method in biogeography to resolve this problem when analyzing areas of endemism (Morrone and Carpenter, 1994; Flores-Villela and Goyenechea, 2001; Contreras et al., 2007), but see Brooks (2005) and Hales et al. (2005).

Another source of incongruence may be that Mexico has been considered as a biogeographic transition zone (Halffter, 1961, 1964, 1978, 1987; Morrone, 2006). Morrone (2006) proposed 2, the Nearctic and the Mexican transition zones, and stated that transition zones are located at boundaries between biogeographic regions, and represent areas of biotic overlap, moreover stating that "...in cladistic biogeographic analyses, putative transition zones should give conflicting results because they result in sister areas with different biogeographic areas" (Morrone, 2006). In particular, the Mexican transition zone of Morrone (2006) includes the following provinces: Sierra Madre

Occidental, Sierra Madre Oriental, Transmexican Volcanic Belt, Balsas Basin, and Sierra Madre del Sur (Morrone, 2005, 2006). In the present analysis, these provinces maintain different positions in the different GAC's (see Figs. 1, 4 and 7). The Balsas Basin is included into the area represent as PCBAL (see Fig. 2). The PCBAL area present different positions in different GAC's (see Figs. 1, 4 and 7), it is sister to SMOR (Fig. 1), or is located in basal position to the clade (TAMS(CHIG((SMOR + SMOC) + (DSON + DCHI)))) (Fig. 4), or corresponds as sister region to (SMEX + TVA) (Fig. 7). The results presented here show the complexity of the biogeographical history of the region. It may be concluded that we are dealing with different biogeographic scenarios and there is still the need for a reliable methodology in cladistic biogeography to sort them out.

Acknowledgements

OFV thanks to E. Ezcurra, M. Montellano, S. Purata, L. Bojórquez, J. Llorente, B. Kohlman and R. Dirzo. To C. J. McCoy†, H. M. Smith, J. W. Sites, J. Savage, J. Terborgh, J. Soberón, V. Sánchez-Cordero, A. Nieto Montes de Oca, H. Ponce, A. Navarro and H. Benítez. Special thanks to Dr. J. Crisci, for his mentoring in biogeography. For their help with the English translation of this work, to D. Harris†, D. Dosselman, S. Jordan, and J. W. Streicher. Also the kind review and comments of B. Crother and R. Contreras Medina, on a previous version of this manuscript. EAMS thanks to CONACyT and DGEP-UNAM for their support in the form of scholarships, and also to CONACyT for providing her postdoctoral fellowship.

Literature cited

- Adest, G. A. 1977. Genetic relationships in the genus *Uma* (Iguanidae). *Copeia* 1977:47-52.
- Axelrod, D. I. 1975. Evolution and biogeography of Madrean-Tethyan sclerophyll vegetation. *Annals of the Missouri Botanical Garden* 62:280-334.
- Bezy, R. L. and J. W. Sites. 1987. A preliminary study of allozyme evolution in the lizard family Xantusiidae. *Herpetologica* 43:280-292.
- Brooks, D. R. 1990. Parsimony analysis in historical biogeography and coevolution: methodological and theoretical update. *Systematic Zoology* 39:14-30.
- Brooks, D. R. 2005. Historical biogeography in the age of complexity: expansion and integration. *Revista Mexicana de Biodiversidad* 76: 79-94.
- Brooks, D. R., M. G. P. Van Veller and D. H. McLennan. 2001. How to do BPA, really. *Journal of Biogeography* 38: 345-358.

- Brown, K. S. 1987. Biogeography and evolution of neotropical butterflies. *In* Biogeography and quaternary history in tropical America, T. C. Whitmore and G. T. Prane (eds.). Clarendon Press, Oxford. p. 66-104.
- Bryson, R.W., A. Nieto-Montes de Oca and J. Reyes Velasco. 2008. Phylogenetic Position of *Porthidium hespere* (Viperidae: Crotalinae) and Phylogeography of Arid-Adapted Hognosed Pitvipers Based on Mitochondrial DNA. *Copeia* 1:172-178
- Cadle, J.E. 1985. The neotropical colubrid snake fauna (Serpentes: Colubridae): lineage components and biogeography. *Systematic Zoology* 34:1-20.
- Campbell, J. A. 1984. A new species of *Abronia* (Sauria: Anguillidae) with comments on the herpetogeography of the highlands of Southern México. *Herpetologica* 40:373-381.
- Campbell, J. A. and D. R. Frost. 1993. Anguillid lizards of the genus *Abronia*: revisionary notes, descriptions of four new species, a phylogenetic analysis, and key. *Bulletin of the American Museum of Natural History* 216:1-121.
- Colinvaux, P.A., P. E. de Oliveira and M. B. Bush. 2000. Amazonian and Neotropical plant communities on glacial time scales: The failure of the aridity and refuge hypothesis. *Quaternary Science Reviews* 19:141-169.
- Contreras-Medina, R., I. Luna-Vega and J. J. Morrone. 2007. Gymnosperms and cladistic biogeography of the Mexican Transition Zone. *Taxon* 56:905-915.
- Cracraft, J. 1986. Origin and evolution of continental biotas: speciation and historical congruence within the Australian avifauna. *Evolution* 40:977-996.
- Cracraft, J. and R. O. Prum. 1988. Patterns and processes of diversification: speciation and historical congruence in some neotropical birds. *Evolution* 42:603-620.
- Crawford, A. J. and E. N. Smith. 2005. Cenozoic biogeography and evolution in direct-developing frogs of Central America (Leptodactylidae: Eleutherodactylus) as inferred from a phylogenetic analysis of nuclear and mitochondrial genes. *Molecular Phylogenetics and Evolution* 35:536-555.
- Croizat, L. 1958. Panbiogeography: Vols. 1 y 2. Published by author, Caracas. 1731 pp.
- Crother, B. I., J. A. Campbell and D. M. Hillis. 1992. Phylogeny and historical biogeography of the palm vipers, genus *Bothriechis*: biochemical and morphological evidence. *In* Biology of pit vipers, J. A. Campbell and E. D. Brodie Jr. (eds.). La Selva Publications, Tyler, Texas. p. 1-19.
- Crother, B. I., M. M. Miyamoto and W. F. Presch. 1986. Phylogeny and biogeography of the lizard family Xantusiidae. *Systematic Zoology* 35:37-45.
- Delgadillo M., C. 1979. Mosses and phytogeography of the *Liquidambar* forest of Mexico. *The Bryologist* 82:432-449.
- Delgadillo M., C. 1986. The Meso-American element in the moss flora of Mexico. *Linbergia* 12:121-124.
- Delgadillo M., C. 1987. Moss distribution and the phytogeographical significance of the Neovolcanic Belt of Mexico. *Journal of Biogeography* 14:69-78.
- De Souza, D. 2001. Refuge model simulations. Testing the theory. *Revista Brasileira de Entomologia* 35: 803-812.
- Devitt T. J. 2006. Phylogeography of the western lyresnake (*Trimorphodon biscutatus*): testing aridland biogeographical hypotheses across the Nearctic-Neotropical transition. *Molecular Ecology* 15:4387-4407.
- Duellman, W. E. 1960. A distributional study of the amphibians of the Isthmus of Tehuantepec, México. University of Kansas Publications Museum of Natural History 13:19-72.
- Duellman, W. E. 1966. The Central American herpetofauna: an ecological perspective. *Copeia*, 1966:700-719.
- Duellman, W. E. 1970. The hylid frogs of Middle America. *Mongraphs Museum of Natural History University of Kansas* 1:1-753.
- Dunn, E. R. 1931. The herpetological fauna of the Americas. *Copeia*, 1931:106-119.
- Escalante-Pliego, P., A. Navarro-Sigüenza and T. A. Peterson. 1993. A geographic, ecological and historical analysis of land bird diversity in Mexico. *In* Biological diversity of Mexico: origins and distributions, T. P. Ramamoorthy, R. Bye, A. Lot and J. Fa. (eds.). Oxford University Press, New York. p. 281-307.
- Flores-Villela, O. 1991. Análisis de la distribución de la herpetofauna de México. Ph. D. Dissertation, Facultad de Ciencias Universidad Nacional Autónoma de México. México D. F. 269 p.
- Flores-Villela, O. 1993. The herpetofauna of Mexico, distribution and endemism. *In* Biological diversity of Mexico: origins and distributions, T. P. Ramamoorthy, R. Bye, A. Lot and J. Fa. (eds.). Oxford University Press, New York. p. 253-280.
- Flores-Villela, O. y P. Gerez, 1994. Biodiversidad y conservación en México: vertebrados, vegetación y uso del suelo. UNAM-CONABIO México. 439 p.
- Flores-Villela, O. and I. Goyenechea. 2001. A comparison of hypotheses of historical area relationships for Mexico and Central America, or in search for the lost pattern. *In* Mesoamerican Herpetology: systematics, zoogeography, and conservation, J. Johnson, R.G. Webb and O. Flores-Villela (eds.). Centennial Museum, Special Publication University of Texas, El Paso 1:171-181.
- Flores-Villela, O. y A. Muñoz-Alonso. 1993. Anfibios y reptiles. *In* Historia Natural del Parque Ecológico Estatal Omiltemi, Chilpancingo, Guerrero, México, I. Luna y J. Llorente-Bousquets (eds.). CONABIO-UNAM, México, D.F. p. 411-442.
- Gadow, H. 1905. The distribution of Mexican amphibians and reptiles. *Proceedings Zoological Society of London* 1905:191-244.
- Gentry, A. H. 1982. Neotropical floristic diversity: phytogeographical connections between Central and South America, Pleistocene climatic fluctuations, or an accident of the Andean orogeny. *Annals of the Missouri Botanical Garden* 69:557-593.
- Good, D. A. 1988. Phylogenetic relationships among Gerrhonotine lizards: an analysis of external morphology. University of California Publications in Zoology 121:1-139.
- Grismer, L. L. 1988. Geographic variation, taxonomy, and biogeography of the anguillid genus *Elgaria* (Reptilia: Squamata) in Baja California, Mexico. *Herpetologica* 44:431-439.
- Grismer, L. L. 2002. Amphibians and reptiles of Baja California, including its Pacific islands, and the islands in the Sea of

- Cortés. University of California Press. 399 p.
- Halas, D., D. Zamparo and D. R. Brooks. 2005. A protocol for studying biotic diversification by taxon pulses. *Journal of Biogeography* 32: 249-260.
- Halffter, G. 1961. Explicación preliminar de la distribución geográfica de los Scarabaeidae mexicanos. *Acta Zoológica Mexicana* 5:1-17.
- Halffter, G. 1964. La entomofauna americana, ideas acerca de su origen y distribución. *Folia Entomológica Mexicana* 6:1-108.
- Halffter, G. 1976. Distribución de los insectos en la Zona de Transición Mexicana. Relaciones con la entomofauna de Norteamérica. *Folia Entomológica Mexicana* 35:1-64.
- Halffter, G. 1978. Un nuevo patrón de dispersión en la Zona de Transición Mexicana: el Mesoamericano de Montaña. XII Congreso Nacional de Entomología. *Folia Entomológica Mexicana* 39-40:219-222.
- Halffter, G. 1987. Biogeography of the Montane Entomofauna of Mexico and Central America. *Annual Review of Entomology* 32:95-114.
- Hanken, J. and D. B. Wake. 1982. Genetic differentiation among Plethodontid salamanders (genus *Bolitoglossa*) in Central and South America: implications for the South American invasion. *Herpetologica* 38:272-287.
- Hendrickson, D. A. 1986. Congruence of Bolitoglossine biogeography and phylogeny with geologic history: paleotransport on displaced suspect terranes?. *Cladistics* 2:113-129.
- Hillis, D. M. and R. De Sá. 1988. Phylogeny and taxonomy of the *Rana palmipes* group (Salientia: Ranidae). *Herpetological Monographs* 2:1-26.
- Hillis, D. M., J. S. Frost and D. A. Wright. 1983. Phylogeny and biogeography of the *Rana pipiens* complex: a biochemical evaluation. *Systematic Zoology* 32:132-143.
- Hodges, W. L. and K. R. Zamudio. 2004. Horned lizard (*Phrynosoma*) phylogeny inferred from mitochondrial genes and morphological characters: understanding conflicts using multiple approaches. *Molecular Phylogenetics and Evolution* 31: 961-971
- Johnson, J. D. 1989. A biogeographic analysis of the herpetofauna of Northwestern nuclear Central America. *Contributions in Biology and Geology Milwaukee Public Museum* 76:1-66.
- Johnson, J. D. 1990. Biogeographic aspects of the herpetofauna of the Central Depression of Chiapas, México, with comments on surrounding areas. *Southwestern Naturalist* 35:268-278.
- Knapp, S. and J. Mallet. 2003. Refuting refugia?. *Science* 300:71-72.
- Kohlmann, B. and G. Halffter. 1988. Cladistic and biogeographical analysis of *Ateuchus* (Coleoptera: Scarabaeidae) of Mexico and the United States. *Folia Entomológica Mexicana* 74:109-130.
- Lamb, T.; J. C. Avise and J. W. Gibbons. 1989. Phylogeographic patterns in mitochondrial DNA of the desert tortoise (*Xerobates agassizi*), and evolutionary relationships among the North American gopher tortoises. *Evolution* 43:76-87.
- Leaché, A. D. and D. G. Mulcahy. 2007. Phylogeny, divergence times and species limits of spiny lizards (*Sceloporus magister* species group) in western North American deserts and Baja California. *Molecular Ecology* 16:5216-5233.
- Lee, J. C. 1980. An ecogeographic analysis of the herpetofauna of the Yucatan Peninsula. *Miscellaneous Publications University of Kansas Museum Natural History* 67:1-75.
- Legler, J. M. 1990. The genus *Pseudemys* in Mesoamerica: taxonomy, distribution, and origins. *In* Life history and ecology of the slider turtle, J. W. Gibbons (ed.). Smithsonian Institution Press, Washington D.C. p. 82-105.
- Lewis, W. H. 1971. High floristic endemism in low cloud forest of Panama. *Biotropica* 3:78-80.
- Liebherr, J. K. 1991. A general area cladogram for montane Mexico based on distributions in the Platynine genera *Elliptoleus* and *Calathus* (Coleoptera:Carabidae). *Proceedings Entomological Society of Washington* 93:390-406.
- Llorente, J. 1983. Sinopsis sistemática y biogeográfica de los Dismorphinae de México con especial referencia al género *Enatia* Huebner (Lepidoptera: Pieridae). *Folia Entomológica Mexicana* 58:1-207.
- Luna-Vega, I. 2008. Aplicaciones de la biogeografía histórica a la distribución de las plantas mexicanas. *Revista Mexicana de Biodiversidad* 79:217-241.
- Lynch, J. D. 1988. Refugia. *In* Analytical biogeography: an integrated approach to the study of animal and plant distributions, A. A. Myers and P. S. Giller (eds.). Chapman and Hall, London. p. 311-342.
- Marshall, C. J. and J. K. Liebherr. 2000. Cladistic biogeography of the Mexican transition zone. *Journal of Biogeography* 27: 203-216.
- Martin, P. S. and B. E. Harrel. 1957. The pleistocene history of temperate biotas in Mexico and Eastern United States. *Ecology* 38:468-480.
- Mayr, E. 1946. History of the North American bird fauna. *The Wilson Bulletin*, 58:3-41.
- Milstead, W. W. 1967. Fossil box turtles (*Terrapene*) from Central North America, and box turtles from eastern Mexico. *Copeia* 1967:168-179.
- Montanucci, R. R. 1987. A phylogenetic study of the horned lizards, genus *Phrynosoma*, based on skeletal and external morphology. *Contributions in Science Los Angeles County Museum Natural History* 390:1-36.
- Morafka, D. J. 1977. A biogeographic analysis of the Chihuahuan desert through its herpetofauna. *Biogeographica* Vol. IX. Dr. W. Junk B. V. Publishers, The Hague. 313 p.
- Morrone, J. J. 2005. Hacia una síntesis biogeográfica de México. *Revista Mexicana de Biodiversidad* 76:207-252.
- Morrone, J. J. 2006. Biogeographic areas and transition zones of Latin America and the Caribbean islands Based on panbiogeographic and cladistic analyses of the entomofauna. *Annual Review of Entomology* 51:467-94.
- Morrone, J. J., D. Espinosa, C. Aguilar and J. Llorente 1999. Preliminary classification of the Mexican biogeographic provinces: a parsimony analysis of endemism based on plant, insect, and bird taxa. *Southwestern Naturalist* 44:507-14.
- Morrone, J. J. y J. V. Crisci. 1994. Historical biogeography: introduction to methods. *Annual Review of Ecology and Systematics* 26:373-401.

- Murphy, R. W. 1983. Paleobiogeography and genetic differentiation of the Baja California herpetofauna. Occasional Papers of the California Academy of Sciences 137: 1-48.
- Myers, C. W. 1974. The systematics of *Rhadinaea* (Colubridae), a genus of New World snakes. Bulletin of the American Museum of Natural History 153:1-262.
- Noonan, G. R. 1988. Biogeography of North American and Mexican insects, and a critique of vicariance biogeography. Systematic Zoology 37:366-384.
- Nelson, G. 1979. Cladistic analysis and synthesis: Principles and definitions with a historical note on Adanson's families des plantes (1763-1764). Systematic Zoology 28:1-21.
- Page, R. D. M. 1993 COMPONENT. User's manual. Release 2.0. The Natural History Museum, Londres.
- Page, R. D. M. 1994. Maps between trees and cladistic analysis of historical associations among genes, organisms, and areas. Systematic Biology 43:58-77.
- Parra-Olea, G., M. Garcia-Paris, T. J. Papenfuss and D. B. Wake. 2005. Systematics of the *Pseudoeurycea bellii* (Caudata: Plethodontidae) species complex. Herpetologica 6:145-158.
- Pelcastre-Villafuerte, L. and O. Flores-Villela. 1992. Lista de especies y localidades de recolecta de la herpetofauna de Veracruz, México. Publicaciones especiales del Museo de Zoología, Facultad de Ciencias, UNAM 4:25-96.
- Pérez-Higareda, G., R. C. Vogt and O. A. Flores-Villela. 1987. Lista anotada de los anfibios y reptiles de la región de Los Tuxtlas, Veracruz. Instituto de Biología UNAM, México. 23 p.
- Ramamoorthy, T. P. and D. H. Lorence. 1987. Species vicariance in the Mexican flora and description of a new species of *Salvia* (Lamiaceae). Bulletin du muséum d'histoire naturelle. Paris, 4, 9, B, (2):167-175.
- Reyes Castillo, P. 1982. Análisis zoogeográfico de los Passalidae (Coleoptera: Lamellicornia) en la Zona de Transición Mexicana. In Zoología Neotropical, P. J. Salinas (ed.). Actas de VIII Congreso Latinoamericano de Zoología, Venezuela, Tomo 2:1387-1397.
- Reyes Castillo, P. y G. Halffter. 1978. Análisis de la distribución geográfica de la tribu Proculini (Coleoptera, Passalidae). XII Congreso Nacional de Entomología. Folia Entomológica Mexicana 39-40:222-226.
- Riddle B. R. and D. J. Hafner. 2006. A step-wise approach to integrating phylogeographic and phylogenetic biogeographic perspectives on the history of a core North American warm deserts biota. Journal of Arid Environments 66:435-461.
- Riddle B. R., D. J. Hafner, L. F. Alexander and J. R. Jaeger. 2000. Cryptic vicariance in the historical assembly of a Baja California Peninsular Desert biota. Proceedings of the National Academy of Sciences, USA 97:14438-14443.
- Riddle, B. R. and R. L. Honeycutt. 1990. Historical biogeography in North American arid regions: an approach using mitochondrial-DNA phylogeny in grasshopper mice (Genus *Onychomys*). Evolution 44:1-15.
- Rosen, D. E. 1976. A vicariance model of Caribbean biogeography. Systematic Zoology 24:431-464.
- Rosen, D. E. 1978. Vicariant Patterns and Historical Explanation in Biogeography. Systematic Zoology 27:159-188.
- Rosen, D. E. 1985. Geological hierarchies and biogeographic congruence in the Caribbean. Annals of the Missouri Botanical Garden 72:636-659.
- Rzedowski, J. and R. McVaugh. 1966. La vegetación de la Nueva Galicia. Contributions from the University of Michigan Herbarium 9:1-123.
- Sage, R. D., E. M. Prager and D. M. Wake. 1982. A cretaceous divergence time between pelobatid frogs (*Pelobates* and *Scaphiopus*): immunological studies of serum albumin. Journal of Zoology London 198:481-494.
- Savage, J. M. 1960. Evolution of a peninsular herpetofauna. Systematic Zoology 9:184-211.
- Savage, J. M. 1966. The origins and history of the Central American Herpetofauna. Copeia 4:719-766.
- Savage, J. M. 1974. The isthmian link and the evolution of neotropical mammals. Contributions in Science Los Angeles County Museum Natural History (260):1-51.
- Savage, J. M. 1982. The enigma of the Central American herpetofauna: dispersal or vicariance?. Annals of the Missouri Botanical Garden 69:464-547.
- Savage, J. M. 1987. Systematics and distribution of the Mexican and Central American rainfrogs of the Eleutherodactylus gollmeri group (Amphibia). Fieldiana: Zoology. New Series 33:1-57.
- Schmidt, K. P. 1943. Corollary and comentary for "Climate and Evolution". The American Midland Naturalist 30:241-253.
- Shaffer, H. B. 1984. Evolution in a paedomorphic lineage. I an electrophoretic analysis of the mexican ambystomatid salamanders. Evolution 38:1194-1206.
- Sites, J. W, R. L. Bezy and P. Thompson, 1986. Nonrandom expression of lactate dehydrogenase isozymes in the lizard family Xantusiidae. Biochemical Systematics and Ecology 14:539-545.
- Smith, H. M. 1949. Herpetogeny in Mexico and Guatemala. Annals of the Association of American Geographers 39:219-238.
- Stuart, L. C. 1966. The environment of Central American cold-blooded vertebrate fauna. Copeia 4:684-689.
- Swofford, D. L. 2002. PAUP* Phylogenetic analysis using parsimony (and other methods) Version 4.0b8. Sinauer Associates, Sunderland, Massachusetts.
- Toledo, V. M. 1982. Pleistocene Changes of Vegetation in Tropical Mexico. In Biological diversification in the tropics, G. T. Prance (ed.). Columbia University Press., New York. p. 93-111.
- Toledo-Manzur, C. A. 1982. El género *Bursera* (Burseraceae) en el estado de Guerrero. Bachelor thesis, Facultad de Ciencias Universidad Nacional Autónoma de México. México D. F. 182 p.
- Van Devender, T. R. and N. T. Tessman. 1975. Late Pleistocene snapping turtles (*Chelydra serpentina*) from southern Nevada. Copeia 2:249-253.
- Wake, D. B. 1987. Adaptative radiation of salamanders in Middle American cloud forest. Annals of the Missouri Botanical Garden 74:242-264.
- Wake, D. B. and J. F. Lynch. 1976. The distribution, ecology, and evolutionary history of plethodontid salamanders in tropical

- America. Natural History Museum of Los Angeles County Science Bulletin 25:1-65.
- Wake, D. B. and J. F. Lynch. 1982. Evolutionary relationships among Central American salamanders of the *Bolitoglossa franklini* group, with a description of a new species from Guatemala. *Herpetologica* 38:257-272.
- Webb, D. S. 1977. A history of savanna vertebrates in the new world. Part I: North America. *Annual Review of Ecology and Systematics* 8:355-380.
- Wendt, T. 1989. Las selvas de Uxpanapa, Veracruz-Oaxaca, México: evidencia de refugios florísticos Cenozoicos. *Anales del Instituto de Biología. Universidad Nacional Autónoma de México, Serie Botánica* 58:29-54.
- Werman, S. 1992. Phylogenetic relationships of Central and South American pitvipers of the genus *Bothrops* (sensu lato): cladistic analyses of biochemical and anatomical characters. *In* *Biology of the Pitvipers*, J. A. Campbell and E. D. Brodie, Jr. (eds.). Selva, Tyler, Texas. p. 21-40.
- Wiley, E. O. 1988. Parsimony analysis and vicariance biogeography. *Systematic Zoology* 37:271-290.
- Willis, K. J. and R. J. Whittaker. 2000. The refugial debate. *Science* 287:1406-1407.
- Wojcicki, M. and D. R. Brooks. 2004. Escaping the matrix: A new algorithm for phylogenetic comparative studies of coevolution. *Cladistics* 20:341-361.
- Wojcicki, M. and D. R. Brooks. 2005. PACT: an efficient and powerful algorithm for generating area cladograms. *Journal for Biogeography* 32:755-774
- Zandee, M. and M. C. Ross. 1987. Component-compatibility in historical biogeography. *Cladistics* 3:305-332.
- Zaldívar-Riverón, A., V. León-Règagnon and A. Nieto-Montes de Oca. 2004. Phylogeny of the Mexican coastal leopard frogs of the *Rana berlandieri* group based on mtDNA sequences. *Molecular Phylogenetic and Evolution* 30:38-49.