

## FIVE NEW MEXICAN SPECIES OF THE FLEA GENUS *STREPSYLLA* TRAUB, 1950 (SIPHONAPTERA: CTENOPHTHALMIDAE: NEOPSYLLINAE: PHALACROPSYLLINI) WITH A PHYLOGENETIC ANALYSIS

Roxana Acosta

Museo de Zoología "Alfonso L. Herrera", Departamento de Biología Evolutiva, Facultad de Ciencias, Universidad Nacional Autónoma de México, Apdo. Postal 70-399, 04510 México, D. F., México. e-mail: roxana\_a2003@yahoo.com.mx

**ABSTRACT:** The genus *Strepsylla* Traub is redescribed and compared with the other genera of the tribe Phalacropsyllini. Thirteen recognized species are distributed in Mexico, Guatemala, Honduras, Costa Rica, and Panama, where they parasitize small rodents, especially mice of the genus *Peromyscus*. Five new species are reported and described (*Strepsylla ixtlanensis* n. sp., *Strepsylla longicauda* n. sp., *Strepsylla queretana* n. sp., *Strepsylla tezontli* n. sp., and *Strepsylla vargasi* n. sp.). Keys for the genera of the tribe and for the species of *Strepsylla* are included, and relevant notes for each species are given. A cladistic analysis of *Strepsylla* led to the recognition of 2 clades: one includes *S. mina*, *S. villai*, and *S. tezontli*, which are distributed along the Trans-Mexico Volcanic Belt; and the other includes the remaining species, which have a northern Mexico distribution.

Members of the tribe Phalacropsyllini are mostly found in the New World, although a few species are found in Europe (Hopkins and Rothschild, 1962). The tribe has 6 genera with 57 species; all but 4 species are restricted to the Western Hemisphere, and 2 of these are shared with eastern Siberia (Adams and Lewis, 1995; Lewis and Haas, 2001). *Catallagia* Rothschild 1915 is a Nearctic genus with 17 species, most of which are parasitic on small rodents (Arvicolinae). *Delotelis* Jordan 1937 has 2 species in the Nearctic region, which are also found on voles, principally in nests. *Eptedia* Jordan 1938 has 7 known Nearctic species that parasitize rodents and insectivores. The 17 species of *Meringis* Jordan 1937 are also Nearctic and parasitize arid-adapted heteromyid rodents of the Dipodominae. *Phalacropsylla* Rothschild 1915 has 6 Nearctic species found on woodrats (*Neotoma* spp.).

*Strepsylla* Traub 1950 was the last genus described in the tribe. In 1963, the last species was described, and no further attention was given to the genus, except to report new distribution records. Lewis (1974) states that all the poorly known species of the genus are distributed in Mexico, Guatemala, and Panama. There are 8 known species: *Strepsylla dalmati* Traub and Barrera 1955, *Strepsylla davisae* Traub and Johnson 1952, *Strepsylla fautini* Traub 1950, *Strepsylla machadoi* Barrera and Traub 1963, *Strepsylla mina* Traub 1950, *Strepsylla schmidtii* Traub and Barrera 1955, *Strepsylla taluna* Traub and Johnson 1952, and *Strepsylla villai* Traub and Barrera 1955. They parasitize species of small rodents, especially *Peromyscus*. Medvedev (2000a, 2000b) stated that *Strepsylla* can be considered endemic to the Caribbean subregion and is associated with hosts belonging to 6 genera of Sigmodontinae. Prior to the current revision of *Strepsylla*, 7 of the 8 recognized species were collected in Mexico; however, the tribe is almost completely Nearctic, and this genus represents the southernmost distribution of members of the tribe. Most of the species are found in central Mexico. Acosta and Fernández (2007) observed that the flea and mammal fauna at the generic and specific level in central Mexico are basically boreal. The richness of Siphonaptera fauna in the Trans-Mexican Volcanic Belt is a result of the wide and mountainous territory, which favors the

existence and development of a rich and abundant biota (Morrone, 2006).

My objectives are to provide a cladistic hypothesis for the phylogenetic relationships among the species of *Strepsylla*, to provide taxonomic keys for the genera of the tribe Phalacropsyllini and for the species of *Strepsylla*, to describe new taxa, and to comment on their characteristics.

### MATERIAL AND METHODS

I examined 205 slide-mounted specimens, including the primary types of 5 species and photographed diagnostic structures in lateral view. This study was particularly difficult because of the low number of specimens available. In the case of *S. fautini* and *S. schmidtii*, only the holotypes and paratypes were available. Some of the remaining species have few specimens or records from northern Mexico and the Central American countries. Structural characters used to distinguish the majority of the ctenophthalmid species are found in males. The most stable and representative characters for most species of *Strepsylla* are found in the modified abdominal segments of the male (movable and fixed process, tergite IX, sternite IX, and aedeagus). Slide-mounted specimens were examined with an Olympus Vanox-T microscope (Olympus Corporation, Tokyo, Japan). Digital pictures were taken with a Canon camera (Canon, Inc., Tokyo, Japan), and Adobe Photoshop 4.0 was used to prepare digital images. Distribution maps were drawn using Arc View GIS 3.2 for Windows.

To determine the phylogenetic placement of the new species, 24 characters of the external morphology and male genitalia were scored for the 13 species of *Strepsylla* (Tables I, II). The analysis was undertaken with NONA (Goloboff, 1996) and Winclada (Nixon, 2002). Multistate characters were treated as non-additive, and characters not observed were coded as “-.” A heuristic strategy was used, including multiple TBR + TBR, maximum trees to keep (hold) = 100, number of replications (mult = N) = 20, and starting trees per rep (hold) = 15. The cladograms were rooted with *Neopsylla inopina* and *Eptedia wenmanni*, which belong to closely related genera.

Specimens were obtained on loan from the following institutions: American Museum of Natural History (AMNH), New York, New York; Department of Entomology, British Natural History Museum (BNHM), London, U.K.; Carnegie Museum of Natural History (CMNH), Pittsburgh, Pennsylvania; Laboratorio de Acarología, Instituto de Biología, Universidad Nacional Autónoma de México (IBUNAM), México, D.F., Mexico; BYU Collection, Monte L. Bean Life Science Museum (MLBLSM), Brigham Young University, Provo, Utah; Personal Collection of Ralph Eckerlin (RE), Northern Virginia Community College (NVCC), Annandale, Virginia; Colección de Siphonaptera, Museo de Zoología, Facultad de Ciencias (MZFC-S), Universidad Nacional Autónoma de México, Mexico, D.F., Mexico; and Department of Entomology, National Museum of Natural History, Smithsonian Institution (USNM), Washington, D.C.

Received 20 May 2009; revised 16 October 2009, 23 October 2009, 5 November 2009; accepted 13 November 2009.

DOI: 10.1645/GE-2173.1

TABLE I. Characters and character states used for the cladistic analysis of species of *Strepsylla*.

Character	Description
1	Setae of movable process: (0) shorter than movable process; (1) as long as movable process
2	Semi-membranous flap: (0) short and not surpassing apex of sternite IX; (1) long and surpassing apex of sternite IX
3	Base of sternite IX: (0) rounded; (1) straight
4	Apex of sternite IX: (0) rounded; (1) pointed; (2) truncate (non-additive)
5	Number of setae in the apex of sternite IX: (0) none; (1) one; (2) two; (3) three or more
6	Spiniform bristle at the apex of sternite IX: (0) as long as apical setae; (1) shorter than apical setae
7	Spiniform bristle in the flap: (0) apex not superimposed with base; (1) apex superimposed with base
8	Dorsal margin of fixed process: (0) concave; (1) rounded; (2) straight
9	Distribution of setae at dorsal margin of movable process: (0) from base to apex; (1) apical 2/3; (2) apical 1/3
10	Shape of movable process: (0) more slender than wide; (1) robust, about twice as long as wide
11	Apical half of crochets of aedeagus: (0) simple, without arms; (1) U-shape, both arms with the same length; (2) U-shape, with one arm conspicuously longer than the other
12	Number of long setae on sternite VIII: (0) three or more; (1) two; (2) one
13	Number of lateral setae on profemur: (0) 10; (1) less than 10; (2) more than 10 (non-additive)
14	Number of antepygidial setae: (0) three; (1) two
15	Number of spines in pronotal comb: (1) 14 or more; (0) 12
16	Base of movable process: (0) rounded; (1) straight
17	Constriction in aedeagal apodeme: (0) basal; (1) medial
18	Dorsal margin of the apex of proximal arm of sternite IX: (0) pointed; (1) rounded
19	Number of setae on sternites I–VII: (0) three; (1) four or more
20	Base of dorsal margin of the movable process: (0) smooth; (1) denticulate
21	Shape of the apex of manubrium: (0) straight; (1) sinuate
22	Shape of fixed process: (0) rounded; (1) square
23	Shape of ventral margin of wall of aedeagal pouch: (0) without lobe; (1) with lobe
24	Shape of dorsal lobe: (0) rounded; (1) truncate

**Tribe Phalacroscylini Wagner 1939**

Phalacroscylini Wagner 1939: 89

*Diagnosis:* Fourth link-plate absent; sinus in propleurum for reception of first link-plate differentiated, often well developed; fifth segment of tarsus with 1 pair of plantar setae shifted on plantar surface on at least fore- and midtarsi; and 3 antesensilial setae on each side in female and either 2–3 in male.

**Key to the genera of Phalacroscylini**

- 1. Genal comb absent; Siberia and North America . . . . . 2
- Genal comb with 2 spines; North America . . . . . 3
- 2. Frons with only 2 rows of setae; labial palpus not reaching tip of procoxa . . . . . *Catallagia*
- Frons with 3 rows of setae; labial palpus reaching tip of procoxa . . . . . *Delotelis*
- 3. Frontal tubercle and striatum both absent . . . . . 4
- Frontal tubercle and striatum both present . . . . . 5
- 4. Inner surface of hind coxa with elongate patch of small setae, some of which are weakly spiniform; abdomen with vestigial combs; anterior abdominal terga with spinelets . . . . . *Phalacroscylla*
- Inner surface of hind coxa with a single row of stout spiniform bristles; abdomen without vestigial combs; anterior abdominal terga without spinelets . . . . . *Meringis*
- 5. Segment V of hind tarsus with only lateral pairs of plantar setae; no setae of segment II of hind tarsus reaching apex of segment III; ventral flange of distal arm of sternite IX not feebly sclerotized . . . . . *Epitedia*
- Segment V of hind tarsus with a pair of plantar setae between members of first lateral pair; longest seta of segment II of hind tarsus surpassing apex of segment IV; ventral flange of distal arm of sternite IX feebly sclerotized . . . . . *Strepsylla*

**REDESCRIPTION**

(Figs. 1–58)

***Strepsylla* Traub 1950**

*Diagnosis:* Twisted spiniform bristle on feebly sclerotized ventral flange of distal arm of sternite IX of male highly diagnostic (Fig. 33). Differs from *Catallagia* and *Delotelis* by presence of genal comb, from *Epitedia* by presence of 4 lateral pairs of plantar bristles on segment V of hind tarsi, and from *Meringis* and *Phalacroscylla* by presence of frontal tubercle and striatum. Frontal tubercle, genal comb, abdominal spinelets, and striatum present. Subapical mesal patch of short setae on inner side of hind coxa weakly spiniform. Segment V of all tarsi with 4 lateral pairs of setae; first pair on plantar surface between second pair in all members of genus. Spiracle VIII slender, widening near base of sensillum. Males with flap on sternite IX with looped stout seta and robust movable process. Sternite VII with shallow sinus on females.

Frontal tubercle present. Genal comb consisting of 2 overlapping spiniform bristles. Labial palpus extending distally to fore trochanter. Post-antennal region with 2 rows of approximately 4–(4)5 setae; these rows are preceded by fairly short or long seta near base of scape and antennal fossa. Metacoxa with patch of mesal spinelets. Longest apical seta of third segment of metatarsus extending beyond the fourth segment of metatarsus. Proximal plantar setae of fifth segment of metatarsus shifted. First abdominal tergite with apical spinelets. Two (rarely 3) antesensilial setae in male, 3 in female. Typical terga with 2 rows of setae, both rows extending slightly below of somewhat sagittate spiracle. Sensillum somewhat convex caudally. Proximal ventral sclerite of 10th male abdominal segment with a filamentous tufted projection. Tergite VIII in males arising from region of base of antesensilial setae and directed ventrad to middle of body, then turning caudad as triangular shape and acute apex; anterior margin lightly sclerotized; posterior margin recurving toward conspicuous eighth spiracle. Manubrium very narrow, curved, or bent anteriorly in apical fourth; movable process without spiniform bristles. Sternite IX with distal arm long and narrow, with an apical claw, truncate or rounded, and possessing a feebly sclerotized lateral expansion

TABLE II. Character state matrix of species of *Strepsylla* and *Neopsylla* and *Epitedia* outgroups.

	1	2	3	4	5	6	7	8	9	10	11	12	13	14	15	16	17	18	19	20	21	22	23	24	
<i>Neopsylla</i>	0	–	0	0	0	–	–	0	0	0	0	0	0	0	0	0	0	0	0	0	0	0	0	0	0
<i>Epitedia</i>	0	–	1	0	0	–	–	0	0	1	0	0	1	0	1	0	0	1	1	0	0	1	0	0	0
<i>S. dalmati</i>	0	1	1	2	1	0	0	1	1	1	1	0	1	0	0	1	0	0	1	0	0	1	1	0	0
<i>S. davisae</i>	0	1	0	2	2	0	1	2	1	0	1	2	2	1	1	1	0	0	1	1	1	0	1	1	1
<i>S. fautini</i>	0	1	0	0	2	0	1	0	0	0	0	2	0	1	0	1	0	0	1	0	1	0	0	0	1
<i>S. machadoi</i>	1	1	1	2	2	0	0	0	0	0	0	0	1	0	1	0	1	0	1	0	0	1	0	1	0
<i>S. mina</i>	1	1	1	1	3	1	1	0	1	0	1	2	1	0	1	1	0	0	1	1	1	0	1	0	1
<i>S. schmidtii</i>	0	1	0	0	2	0	0	1	1	0	2	1	0	1	1	0	0	0	1	0	0	1	1	0	0
<i>S. taluna</i>	0	0	0	1	2	1	1	2	0	1	2	2	0	0	0	0	0	0	1	0	1	0	1	0	1
<i>S. villai</i>	0	0	1	1	3	1	0	0	0	1	1	2	1	1	1	0	0	0	1	1	1	0	1	0	0
<i>S. tezonli</i> n. sp.	0	0	1	1	3	1	1	0	0	0	1	1	0	1	0	0	0	0	1	1	1	1	1	1	1
<i>S. longicauda</i> n. sp.	1	0	0	2	2	0	1	2	0	0	2	2	0	1	0	1	0	1	1	1	1	1	1	1	0
<i>S. ixtlanensis</i> n. sp.	0	1	0	2	2	0	1	0	1	0	2	2	1	1	0	1	0	0	1	0	0	1	0	0	1
<i>S. vargasi</i> n. sp.	0	1	1	1	2	0	1	0	0	1	1	1	1	1	0	0	0	0	1	0	1	0	1	0	1
<i>S. queretana</i> n. sp.	0	1	1	2	2	0	1	0	1	0	2	0	0	1	0	1	0	1	0	1	1	0	1	1	1

that bears a characteristic conspicuous curved spiniform bristle like a twisted hook. Crochets appear as ventral lobes of aedeagus. Aedeagal pouch twice the breadth of aedeagal apodeme. Apical sclerites of sclerotized inner tube present. Apodemal rod arising from the junction of proximal and distal arms of sternite IX. Dorsal margin of sternite VII in females slightly sinuous with deep sinus at the base. Female specimens appear very similar and often cannot be distinguished from other species without accompanying males, or, in some cases, they may be identified on the basis of geographic distribution, when those are restricted for the species (Figs. 50, 55, 56, 58) (Traub, 1950).

#### Remarks

These are medium-sized fleas ranging in length from 2 to 4 mm. Species are distributed in Mexico, Guatemala, Honduras, Costa Rica, and Panama, where they parasitize sciurids and small rodents (murids), particularly members of *Peromyscus*. It is possible that they are nest fleas, like other genera of the family (Traub, 1950). These fleas are usually montane species parasitizing small murid rodents belonging to the Neotominae, including species of *Megadontomys* (Merriam), *Neotoma* Say and Ord, *Neotomodon* Merriam, *Peromyscus* Gloger, *Reithrodontomys* Giglioli, and *Microtus* Schrank in the Arvicolinae. *Strepsylla* are not always host specific on this group of mammals and are occasionally found on other small mammals, i.e., rice rats *Oryzomys* Baird (Sigmodontinae), volcano rabbit *Romerolagus diazi* Merriam (Leporidae), and squirrels *Sciurus* Linnaeus (Sciuridae).

#### Key to species of *Strepsylla* (males)

1. Fixed process roughly square (Figs. 13, 15); movable process with posterior margin densely fringed with setae, some of which are exceptionally long (Figs. 15, 20) . . . . . 2
  - Fixed process roughly triangular (Fig. 16); setae on posterior margin of movable process much less dense and not especially long (Figs. 16, 22) . . . . . 4
2. Apex of distal arm truncate (Fig. 25) . . . . . *S. longicauda* n. sp.
  - Apex of distal arm pointed (Figs. 26, 27) . . . . . 3
3. Lateral margin of sternite IX with long seta (Fig. 32) . . . . . *S. machadoi*
  - Lateral margin of sternite IX with short and scattered setae (Fig. 33) . . . . . *S. mina*
4. Dorsal margin of movable process narrow or slightly concave near end (Fig. 16); Guatemala, Honduras, and Costa Rica . . . . . *S. dalmati*
  - Dorsal margin of movable process almost straight or smooth near end (Figs. 18, 19); Mexico . . . . . 5
5. Main portion of distal arm of sternite IX strongly sickle-shaped or falcated with angulated anterior margin (Figs. 27, 28) . . . . . 6
  - Main portion of distal arm of sternite IX less sickle-shaped or with almost straight anterior margin (Figs. 33, 36) . . . . . 10
6. Feebly sclerotized ventral flange of distal arm of sternite IX, not reaching the tip of main portion (Fig. 36) . . . . . 7

- Feebly sclerotized ventral flange of distal arm of sternite IX, extending beyond tip of main portion (Fig. 27) . . . . . *S. vargasi* n. sp.
- 7. Movable process widest well above level of acetabulum (Fig. 22); apex of distal arm of sternite IX with 3 setae (Fig. 36) . . . . . 8
  - Movable process widest at about level of acetabulum (Fig. 14); apex of distal arm of sternite IX with 2 setae (Fig. 31) . . . . . 9
- 8. Abdominal spiracles lanceolate; dorsal margin of movable process straight (Fig. 17) . . . . . *S. villai*
  - Abdominal spiracles blunt, somewhat rounded; dorsal margin of movable process concave . . . . . *S. tezonli* n. sp.
- 9. Apex of dorsal lobes sickle-shaped or truncate (Fig. 39); apex of ventral flange spiculate (Figs. 28, 36); spiniform bristle of sternite IX as long as or longer than apical setae (Figs. 28, 31) . . . . . 11
  - Apex of dorsal lobes rounded (Fig. 48); apex of ventral flange smooth; spiniform bristle of sternite IX shorter than apical setae (Fig. 35) . . . . . *S. taluna*
- 10. Apex of dorsal lobes sickle-shaped or truncate (Fig. 39) . . . . . *S. ixtlanensis* n. sp.
  - Apex of dorsal lobes rounded (Fig. 41) . . . . . *S. queretana* n. sp.
- 11. Spiniform bristle on ventral flange of distal arm of sternite IX relatively small and hooked (Fig. 34); anterior margin of fixed process wholly convex (Fig. 22) . . . . . *S. schmidtii*
  - Spiniform bristle on ventral flange larger and more twisted (Figs. 25, 33); anterior margin of fixed process of clasper partly concave (Figs. 11, 21) . . . . . 12
- 12. Main portion of distal arm of sternite IX almost straight (Fig. 31) and only a little expanded near junction with proximal arm; lateral lobe of aedeagus much longer than broad (Fig. 44) . . . . . *S. fautini*
  - Main portion of distal arm of sternite IX not straight (Fig. 30), markedly expanded near junction with proximal arm; lateral lobe of aedeagus about as broad as long (Fig. 43) . . . . . *S. davisae*

## DESCRIPTIONS

### *Strepsylla tezonli* n. sp.

(Figs. 4, 9, 11, 24, 37, 53, 54, 60)

*General diagnosis* (Fig. 4): First pre-antennal row with 5 small setae; second row of 4 longer setae; third seta nearest eye and shorter than others (female 5–5). Second antennal segment with apical fringe of small setae, not extending beyond segment of fairly symmetrical club. Post-antennal region with 2 rows of 4–5 setae (female 5–6); rows preceded by fairly short seta near base of scape and antennal fossa. Pronotum (Fig. 4) with 1 row of 5–6 large setae per side. Pronotal comb with 14 fairly broad spines. Mesonotum with 3 rows of setae; last row much longer than the others. Mesonotal flange with 4 pseudosetae per side. Mesepimeron with 4 setae, longest near ventral margin. Metanotum

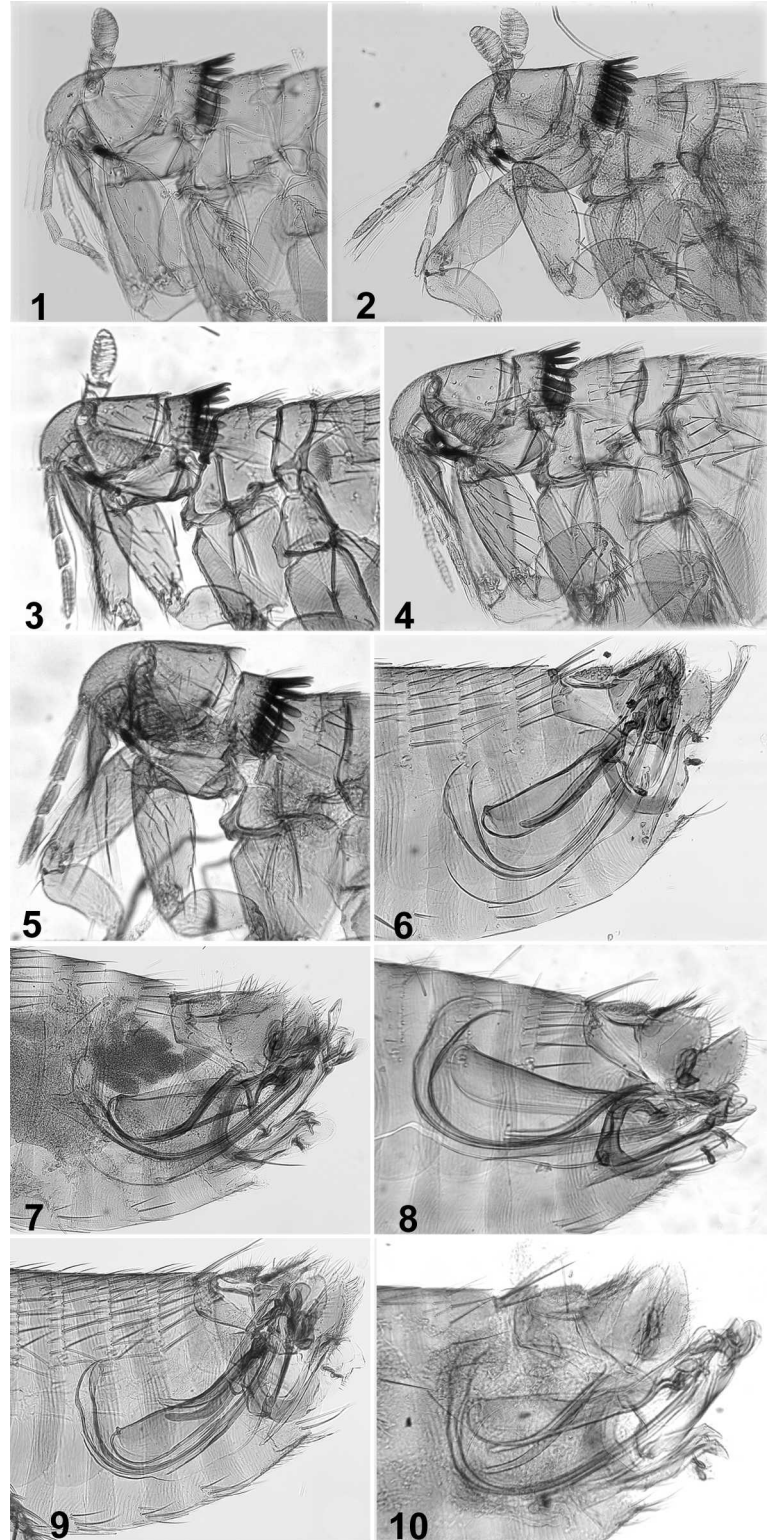

FIGURES 1–10. Male head: (1) *Strepsylla longicauda*; (2) *S. ixtlanensis*; (3) *S. queretana*; (4) *S. tezonli*; (5) *S. vargasi*. Terminal segments male: (6) *S. longicauda*; (7) *S. ixtlanensis*; (8) *S. queretana*; (9) *S. tezonli*; (10) *S. vargasi*.

with 3 rows of setae and anterior of 2–3 small setae; third row larger than the others. Metepisternum with 4 setae near posterodorsal angle; 1 very long and others very short. Profemur with 9–11 small thin lateral setae. Longest setae of tarsus of foreleg on segment I, 2 dorsolateral setae nearly reach apex of second segment. Marginal spinelets on abdominal

segments I–IV as follows: 2–4–2–2 per side. Two antensensorial setae (Fig. 9); dorsal twice as long as ventral. Sternite VIII with row of 2 long setae per side (Figs. 9, 11, 24); about 9 short bristles anterior to row, mainly marginal; posterior margin fairly straight. Fixed process of clasper (Fig. 11) higher than long (broad), with row of thin setae

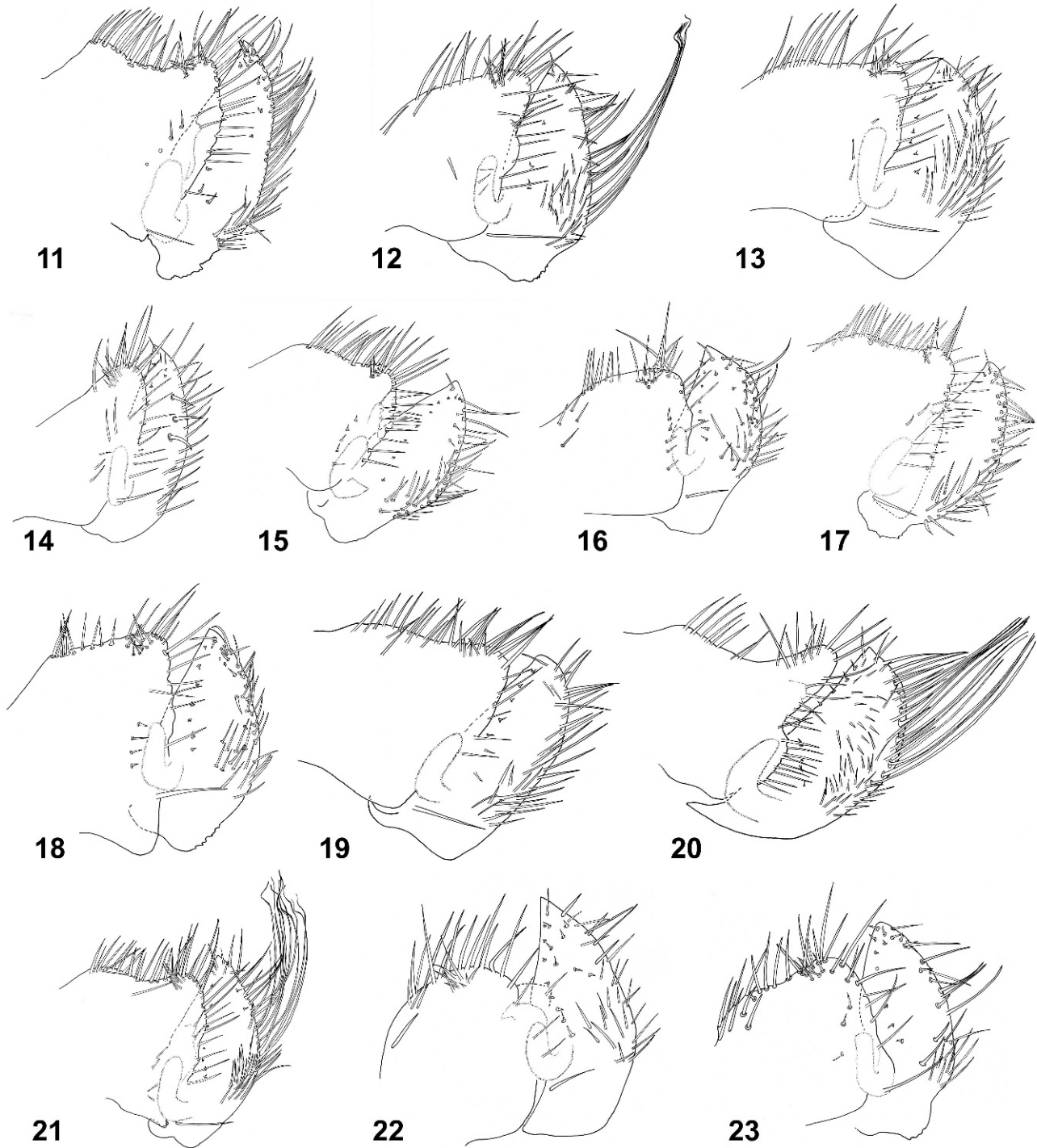

FIGURES 11–23. Movable and fixed process (male): (11) *Strepsylla tezontli*; (12) *S. longicauda*; (13) *S. ixtlanensis*; (14) *S. vargasi*; (15) *S. queretana*; (16) *S. dalmati*; (17) *S. villai*; (18) *S. davisae*; (19) *S. fautini*; (20) *S. machadoi*; (21) *S. mina*; (22) *S. schmidtii*; (23) *S. taluna*.

dorsomarginal, row of setae on caudal margin widely spaced and fewer on distal third only; subapical medial patch of 4–5 small thin curved setae; dorsal margin slightly but evenly concave; anterior hump twice as long as posterior hump; posterior hump with mostly thin setae. Sclerotized process above acetabular region with 2 subdorsal setae. Movable process (Fig. 11) slightly more than twice as long as broad at maximum; anterior margin slightly concave; caudal margin evenly rounded from apex to near end point, but then becoming emarginated as it is somewhat constricted proximally; end of caudal margin serrate or

dentate; ventral margin rounded. Movable process with caudomarginal row of setae extending from apex to beyond midpoint, patch of thin setae at low level of midline; apex with thin scattered small setae, line of 8 submarginal small setae, near anterior margin. Apex of proximal arm of sternite IX with dorsocaudal angle expanded and rounded and equal in length to acute anterodorsal angle. Distal arm of sternite IX longer than proximal arm; apex sickle-shaped with 3 long slender setae (Fig. 24), conspicuous short broad spiniform bristle; marginal row of thin setae on caudal margin. Semi-membranous flap with marginal sinus; with looped

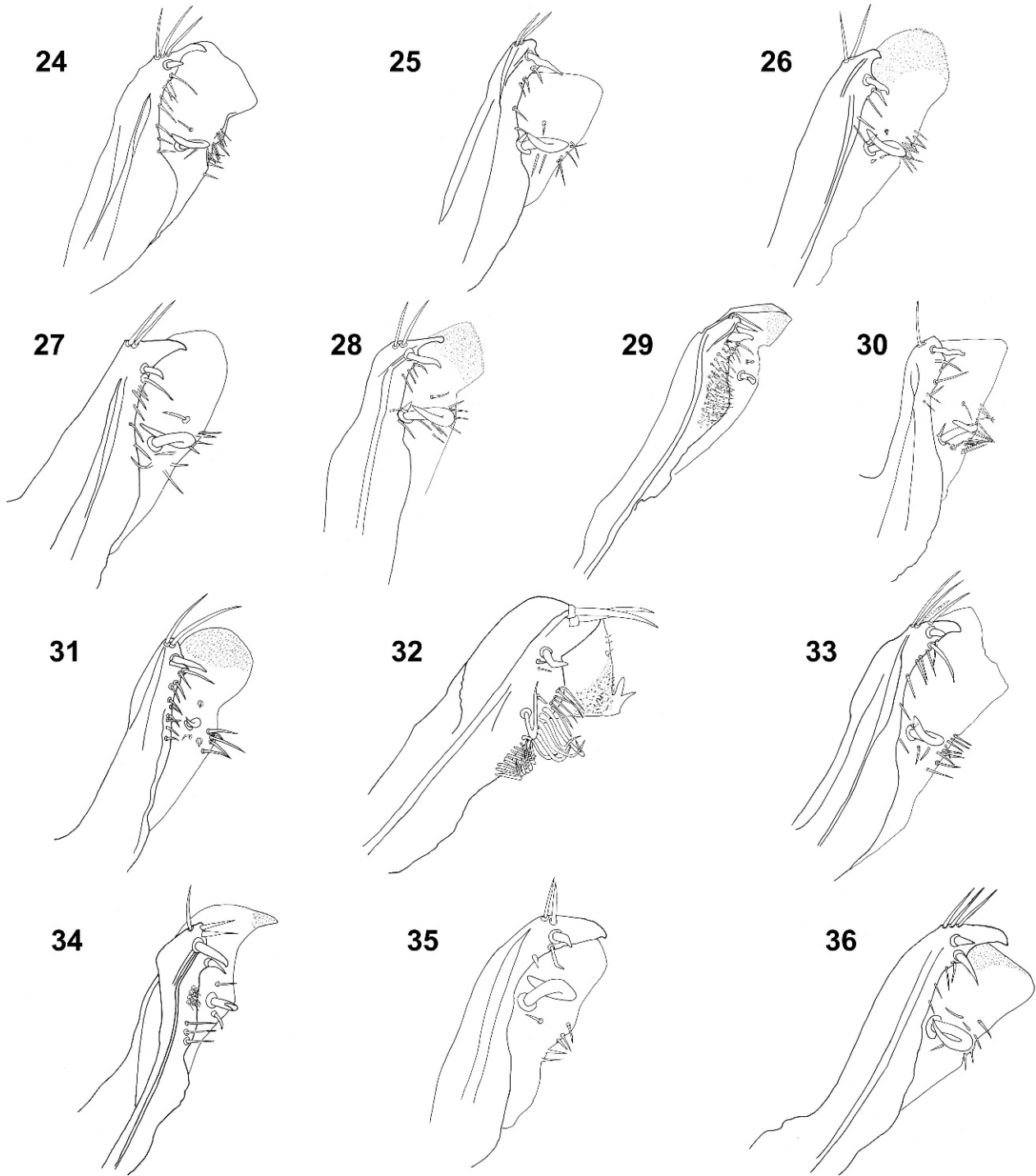

FIGURES 24–36. Male sternite IX: (24) *Strepsylla tezontli*; (25) *S. longicauda*; (26) *S. ixtilanensis*; (27) *S. vargasi*; (28) *S. queretana*; (29) *S. dalmati*; (30) *S. davisae*; (31) *S. fautini*; (32) *S. machadoi*; (33) *S. mina*; (34) *S. schmidtii*; (35) *S. taluna*; (36) *S. villai*.

spiniform bristle; thin setae at level of spiniform bristle (Fig. 24). Base of sternite IX U-shaped, not angulate. Aedeagal apodeme 4 times as long as broad. Base of well-developed aedeagal pouch wall sclerotized with blunt ending. Ventral margin of wall of aedeagal pouch sclerotized. Medial dorsal lobe shallowly sinuate, terminating at apex of rod-like sclerite dorsal to base of sclerotized inner tube. Subapical dorsal lobe fairly differentiated. Distodorsal lobes well developed, 3 times as long as broad, from apex of rod-like sclerite; apically truncate. Lateral lobes of aedeagus

developed and twice as long as broad. Crochets (Fig. 37) large, 1 1/2 times as long as broad; proximal portion broadly ovate; dorsally produced into a long semi-circle, concave; sclerotized portion appearing apically acuminate, and slightly sclerotized. Tergite VIII with row of 3 setae per side near spiracle VIII on females, dorsolateral group of 4 setae, ventro lateral group of 1–2 setae, marginal row of 4 long setae and 2 short setae, and pair of short submarginals. Sternite VII with rounded lobe ending in small depression; 5 lateral setae with 5–6 small anterior

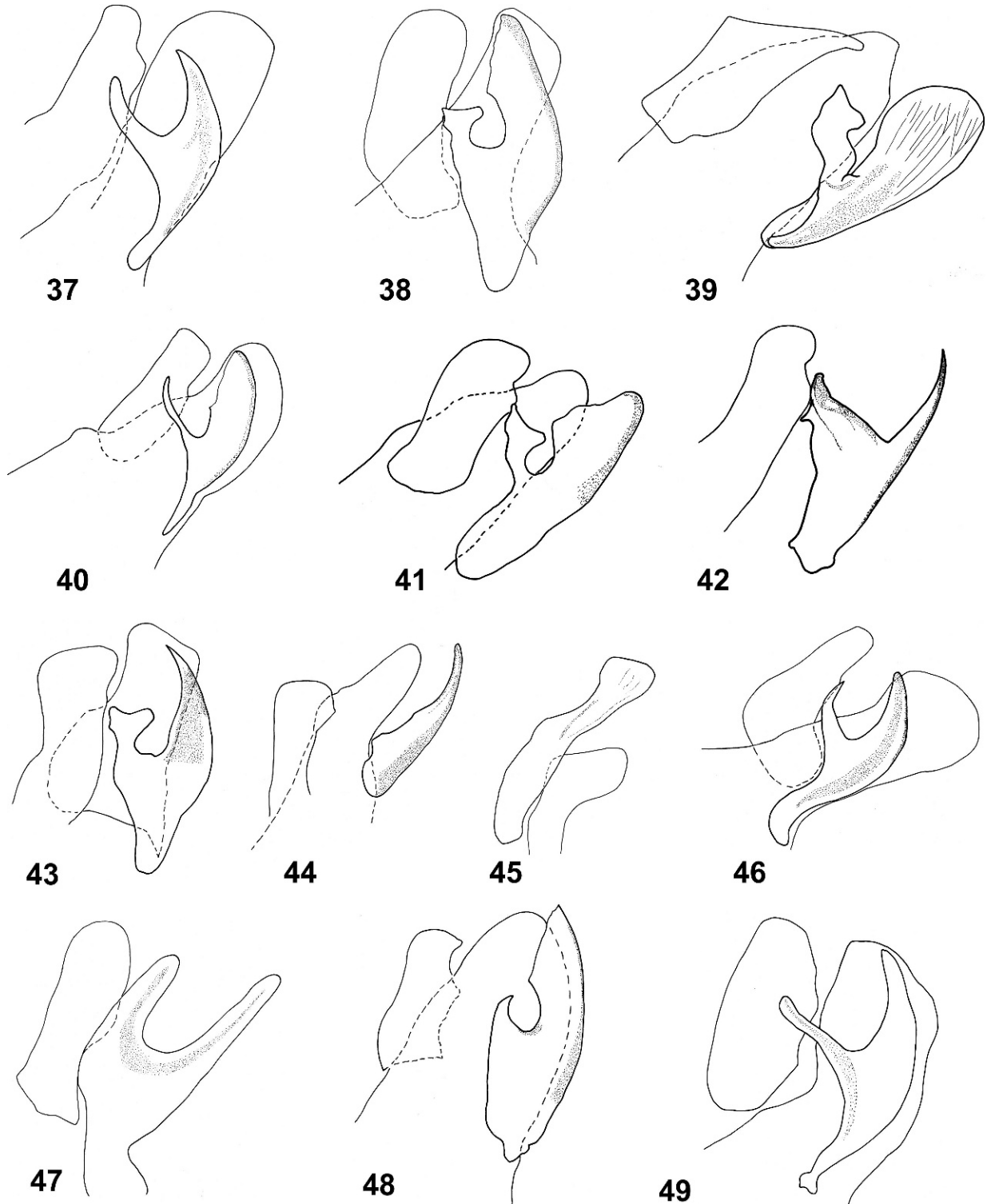

FIGURES 37–49. Male crochets, dorsal lobes, and lateral lobes: (37) *Strepsylla tezontli*; (38) *S. longicauda*; (39) *S. ixtlanensis*; (40) *S. vargasi*; (41) *S. queretana*; (42) *S. dalmati*; (43) *S. davisae*; (44) *S. fautini*; (45) *S. machadoi*; (46) *S. mina*; (47) *S. schmidtii*; (48) *S. taluna*; (49) *S. villai*.

setae (Fig. 53). Sternite VIII without setae. Anal stylet with 1 large seta and 2 tiny lateral setae. Semi-reflected hilla of spermatheca C shaped (Fig. 54); hilla 1 1/2 times as long as bulga; bulga ovoid. Bursa copulatrix sclerotized in the middle, expanded and rounded apex. Three antesensilial setae, middle one twice as long as uppermost and lowermost shorter than the middle one.

#### Taxonomic summary

*Type host*: Unknown.

*Type locality*: Mexico. Popocatepetl: Tlamacas, 3,50 m.

*Types*: Holotype male (0732MZFC-S), 19/X/1963, A. Barrera (see Acosta [2010] for list of paratypes and localities).

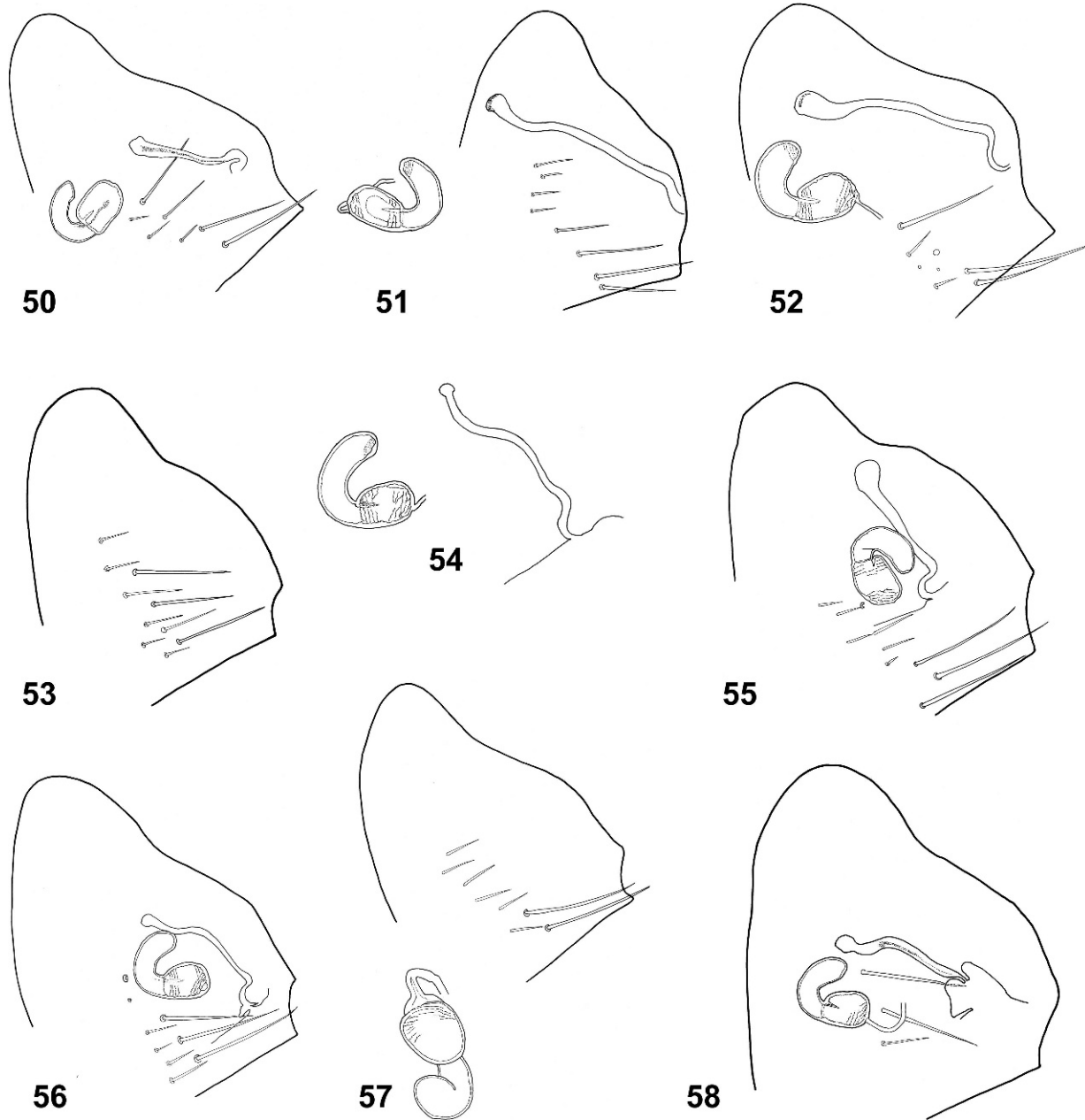

FIGURES 50–58. Sternite VII and spermatheca female: (50) *Strepsylla dalmati*; (51) *S. ixtlanensis*; (52) *S. longicauda*; (53, 54) *S. tezonitli*; (55) *S. machadoi*; (56) *S. mina*; (57) *S. vargasi*; (58) *S. villai*.

*Etymology*: The name tezonitli, a noun in apposition, means “volcanic stone” in Náhuatl.

*Distribution*: Trans-Mexican Volcanic Belt (Fig. 60).

**Remarks**

Neither the host preference nor the distribution can be accurately inferred with the existing data. The apex of sternite IX is sickle-shaped and slender, bearing 3 long setae and a conspicuous short broad spiniform bristle (Fig. 24). There is a semi-membranous flap with a marginal sinus and single looped spiniform bristle (Fig. 24), and a fixed process with a marked concavity in the dorsal margin (Fig. 11), as in *S. mina*. In *S. tezonitli* n. sp., the sinus is more prominent, sternite IX is similar to *S. villai*, but the apex is more slender, slightly hooked, and caudad. The crochet is similar to *S. villai*, but the ventral arm is not as slender as *S. villai* and is wider in *S. mina* (Figs. 46, 49).

***Strepsylla longicauda* n. sp.**

(Figs. 1, 6, 12, 25, 38, 52, 60)

*General diagnosis*: Dorsal margin of male fixed process (Fig. 12) straight instead of somewhat sinuate (Figs. 13, 15), and with dense patch of many thin, short setae. Few long setae on movable process. Long recurved spiniform bristle on distal arm of male sternite IX with 2 slender setae at the apex (Fig. 25). Hyperdevelopment of distodorsal lobes of aedeagus as compared with apparent reduction or lack of development of lateral lobes; dorsal lobes extend well caudad of lateral lobes (Fig. 38).

First pre-antennal row with 5 setae; second row of 4 longest setae; third seta nearest eye shorter than others (Fig. 1). Pedicel with apical fringe of small setae, not extending beyond second segment of fairly symmetrical club. Post-antennal region with 2 rows of 4–5 setae; these rows are preceded by fairly long seta near base of scape. Pronotum (Fig. 1) with 1 row of about 5 large setae per side. Pronotal comb with 14 fairly broad spines. Mesonotum with 3 rows of setae (6–6[8]–6), first not ordered, last



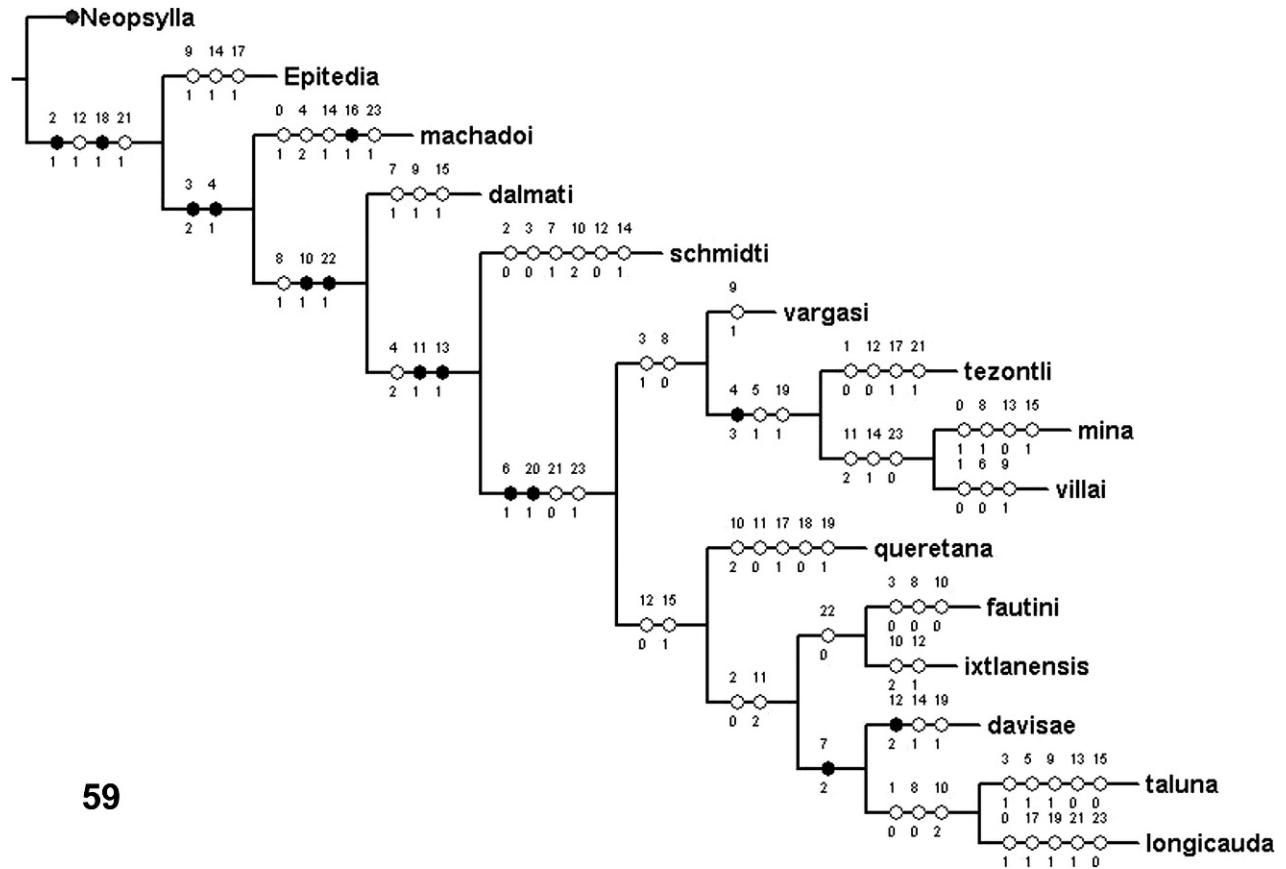

FIGURE 59. Maximum parsimony tree (86 steps, consistency index of 0.36, and retention index of 0.50).

row longer than others. Mesonotal flange with 3 pseudosetae per side. Mesepimeron with 3 setae; 1 near ventral margin longest. Metanotum with 2 rows of setae; anterior 2–3 small setae. Metepisternum 4 setae near posterodorsal angle; 1 very long, the others very short. Metepimeron with anterior row of 4 thin setae and posterior group of 4 stout ones; 3 of the latter quite long. Profemur with 8 small, thin, lateral setae. Longest setae of tarsus of foreleg on segment I; 2 dorsolateral setae reach middle of second segment. Second and third segments of metatarsus with apical seta reaching apex of fourth segment. Tergites with apical spinelets as follows: 2(4)–5–2(4)–1(4). Two antesensilial setae (Fig. 6), dorsal longer than the ventral. Sternite VIII (Fig. 6) of males with 2 long setae per side near ventrocaudal angle; about 7 shorter setae anterior, mainly marginal; posterior margin more or less straight. Fixed process of clasper (Fig. 12) higher than broad, with dorsomarginal row of thin setae, caudomarginal row of similar, but more widely spaced setae reaching middle part, subapical mesal patch of about 8 small thin setae; dorsal margin of fixed process almost straight. Sclerotized process above acetabular region subtruncate, with 3 apicomarginal setae. Movable process (Fig. 12) twice as long as broad; anterior margin more or less straight; caudal margin evenly rounded, widest near midpoint but then becoming emarginated because proximal constriction; ventral margin straight. Movable process with caudomarginal row of setae from apex to midpoint at top; short and longer tufts of thin setae below midline; apical half with thin scattered small setae, some submarginal. Apex of proximal arm of sternite IX with margin straight; dorsocaudal portion of both sides with expanded apex, anterior side pointed, and posterior margin evenly curved. Distal arm of sternite IX as long as proximal arm; apex truncate with 2 long narrow setae and conspicuous long broad spiniform bristle; small thin and scattered setae below these broader semi-membranous flap reaching the apex of distal arm of sternite IX, with proximal curved (looped) spiniform bristle; short thin setae distal to spiniform bristle and others proximal to it (Fig. 25). Aedeagal apodeme 4 times as long as broad. Base of well-developed pouch wall sclerotized, fairly rounded terminally. Ventral

margin of wall of aedeagal pouch weakly sclerotized. Median dorsal lobe thin, shallowly sinuate caudomarginally with small projections or scattered spines, terminating at apex of rod-like sclerite dorsal to base of sclerotized inner tube. Distodorsal lobes well developed, 4 times as long as broad, from apex of rod-like sclerite; apically subtruncate. Lateral lobes of aedeagus developed, truncate, extending beyond apex of sclerotized inner tube. Crochets longer with shape of inverted C (Fig. 38); proximal portion shorter; dorsally longer with narrow apex; sclerotized portion apically acuminate. Armature of inner tube reduced, indiscernible. Tergite VIII with row of 8 setae near spiracle VIII in females, ventrolateral group of 5–7 setae, marginal row of 5 long setae with some short setae intercalary. Sternite VII with rounded lobe ending in sub-concave margin (Fig. 52), row of 4 lateral setae with 6–7 small anterior setae on per side. Sternite VIII with 6–7 setae of different sizes. Major seta of anal stylet about 2 1/2 times as long as base; 1 tiny dorsal seta and 1 ventral thin. Hilla of spermatheca semi-reflected over bulga, as C shape (Fig. 52), hilla 1 1/2 times as long as bulga; bulga ovoid. Bursa copulatrix sclerotized in the middle, expanded and rounded apically, longer than the spermatheca. Two antesensilial setae, dorsal longer than ventral. Sensillum convex.

#### Taxonomic summary

*Type host:* Unknown.

*Type locality:* Mexico. Nuevo León. Cerro Potosí.

*Types:* Holotype male, coll. V. J. Tipton, 1964 (BYU). Paratypes. Mexico. Nuevo León. Cerro Potosí, 1 male ex unknown, V. J. Tipton, 1964 (BYU). Durango. 804 m SE Buenos Aires, 2651 m, 3/VIII/1965, 1 male, 1 female ex *Peromyscus*, J. J. O'Keefe, E. Fisher, and R. Kronmeyer (CMNH). Deposited in BYU collection and CNMH collection.

*Etymology:* The specimen is named for the long setae in the movable process.

*Distribution:* Northern Mexico (Fig. 60).

## Remarks

The female is similar to *S. davisae*; even so, all the females of the genus are indistinguishable. The missing information about the type host species supports the need for additional collection to determine host preferences. The new species is separable from all other known *Strepsylla* in that the dorsal margin of male fixed process (Fig. 12) is straight instead of somewhat sinuate as *S. queretana* and *S. ixtlanensis* (Figs. 13, 15), but size in *S. longicauda* is smaller. The number of long setae on movable process is less than in *S. mina* and *S. machadoi*.

### *Strepsylla ixtlanensis* n. sp. (Figs. 2, 7, 13, 26, 39, 51, 61)

**General diagnosis:** Dorsal margin of male fixed process (Fig. 13) somewhat sinuate instead of convex, or almost straight. Movable process wide. Spiniform bristle large and stout, apex bent, positioned on distal arm of male sternite IX (Fig. 26). Lateral lobes of aedeagus truncate hyperdeveloped (Fig. 39), with 1 end acute, sickle-shaped.

First pre-antennal row (Fig. 2) of males with 6–7 small setae; second row of 4 long setae; third seta nearest eye, shorter than others. Maxillary lobe extending to apex of third segment of maxillary palp. Pedicel with apical fringe of small setae, reaching the third segment of fairly symmetrical club. Post-antennal region with 2 rows of setae (4–5); these rows are preceded by fairly long setae near base of scape. Pronotum (Fig. 2) with 1 row of 5–6 large setae per side. Pronotal comb with 14 fairly broad spines. Mesonotum with 3 rows of setae; last row much larger than the others. Mesonotal flange with 3–4 pseudosetae per side. Mesepimeron with 4 setae, longest near ventral margin. Metanotum with 2 rows of setae, marginal row longest. Metepisternum with 3 setae near posterodorsal angle; 1 very long, the others very short. Metepimeron with anterior row of 3–4 thin setae and posterior group of 4 stout ones, 2 of the latter quite long. Profemur with 9–10 small thin lateral setae. Second segment of metatarsus with apical seta extending near apex of fourth segment. Tergites with apical spinelets as follows: 3(4)–3(4)–3(5)–5–2; some specimens have 4 rows of spinelets. Two antesensillar setae (Fig. 7) dorsal 1/2 again as long as ventral. Sternite VIII of males with 1 long seta per side near ventrocaudal angle (Fig. 7); 8–9 shorter setae at base, mainly marginal; posterior margin slightly sinuate. Fixed process of clasper (Fig. 13) higher than long (broad), with dorsomarginal row of thin setae, caudomarginal row more widely spaced setae on middle margin only, and subapical mesal patch of 6–7 small and long thin setae; dorsal margin slightly straight. Sclerotized process above acetabular region rounded, with 4 apicomarginal setae. Movable process (Fig. 13) slightly more than twice as long as broad at maximum; anterior margin in distal parts lightly sinuate; caudal margin evenly rounded from apex to near endpoint, last part of margin smooth: ventral margin straight. Movable process with caudomarginal row of setae extending from apex to midpoint, with tuft of long slender setae marginal and lateral at level of midline and below; apex with thin scattered small setae; anterior margin with row of 6–7 short setae to midline. Apex of proximal arm of sternite IX (Fig. 26) truncate and expanded, margin straight; dorsocaudal angle expanded and rounded, equal in length to acute anterodorsal angle. Distal arm of sternite IX as long as proximal arm; apex truncate with 2 long slender setae, thin seta above this, with broad spiniform bristle with bent apex; subapical thin medial and submarginal setae below these; semi-membranous flap spiculate apically and longer than distal arm (Fig. 26). Flap with proximal curved (looped) spiniform bristle; patch of short setae proximal to it, almost on margin of flap. Aedeagal apodeme 4 times as long as broad. Base of well-developed aedeagal pouch wall sclerotized, fairly sinuate. Ventral margin of wall of aedeagal pouch sclerotized and apically with slightly ventral hump. Median dorsal lobe rounded, terminating at apex of rod-like sclerite dorsal to base of sclerotized inner tube. Subapical dorsal lobe differentiated. Distodorsal lobes developed, 3 times as long as broad, from apex of rod-like sclerite; apically subrounded. Lateral lobes of aedeagus developed, extending to the apex of dorsal lobe, apex truncate and dorsocaudal angle acute. Crochets longer than broad (Fig. 39); proximal portion slightly truncate; dorsally produced into long broad spur; lightly sclerotized apically. Armature of inner tube visible and sclerotized. Lobes of apodemal strut differentiated, apex truncate. Sternite VII of female with rounded margin; with row of about 5 long setae, preceded by 6 smaller setae (Fig. 51). Tergite VIII with patch of 9 setae above long narrow spiracle; this group extending ventral as a row of 2 small setae and median very long seta at level of dorsal anal lobe;

ventrocaudal region of tergite VIII with setae as follows: 5 long setae bordering subventral sinus; with submedian seta; between these last 2 groups of setae, a patch of about 9 small, fairly thick mesal setae. Sternite VIII is a conical structure bearing 1–2 tiny stout subapical dorsomarginal setae. Dorsal anal lobe of proctiger with dorsomarginal fringe of small setae and 13–14 scattered setae, of which the ventromarginal subapical 1 is long, as is 1 seta inserted at base of anal stylet. Ventral anal lobe not heavily sclerotized, angulated, with about 7 fairly evenly spaced marginal setae, 4 of which are long. Anal stylet 5 times as long as broad, with small dorsomarginal apical seta. Spermatheca (Fig. 51) with hilla longer than bulga; hilla slightly turned over bulga; bulga longer than broad. Bursa copulatrix well developed, with apex (that portion adjoining spermathecal duct) weakly sclerotized.

## Taxonomic summary

**Type host:** *Peromyscus difficilis* (Allen, 1891)

**Type locality:** Mexico, Oaxaca, Ixtlán, 8.75 km SE de Santa María Yavesia, 19°10.2'N, 96°22.5'W, fir forest, 2,990 m.

**Types:** Holotype male 06073 MZFC-S, 24/IV/2002, G. Ambriz. Paratypes (3 males) 06072, 06074, and 06075 MZFC-S, collection of G. Ambriz; the locality and host for these specimens are the same as the holotype. Deposited in MZFC-S.

**Etymology:** The species is named for the locality where the specimens were collected, Ixtlán, in the Mexican state of Oaxaca.

**Distribution:** Southern Mexico (Fig. 61).

## Remarks

The movable process in *S. ixtlanensis* n. sp. is as wide as in *S. dalmati*, *S. taluna*, and *S. queretana*, but the end of dorsal margin is angulated in the new species. The new species is similar to *S. davisae*, by the spiculate flap and the spiniform bristle of the distal arm of sternite IX, and the setae of fixed and movable processes, but the dorsal margin of the flap is almost straight in *S. ixtlanensis*. The hyperdevelopment of lateral lobes is a peculiarity of the new species. Neither the host preference nor the distribution can be accurately inferred with the existing data.

### *Strepsylla vargasi* n. sp.

(Figs. 5, 10, 14, 27, 40, 57, 60)

**General diagnosis:** Movable process (Fig. 14) slender, with row of scattered setae in dorsal margin. Marginal row of thin short setae (Fig. 27) proximal to recurved spiniform bristle on flap of apex of distal arm of male sternite IX; large spiniform bristle apically bent. Conspicuous lateral lobes and broad apex of crochet diagnostic for this species (Fig. 40).

First pre-antennal row of 6–7 small setae in male head (Fig. 5); second row of 4 long setae; third seta nearest eye shorter than others and followed by tiny seta. Maxillary lobe extending to apex of third segment of maxillary palp. Pedicel with apical fringe of small setae, not extending beyond second segment of fairly symmetrical club. Post-antennal region with 2 rows of setae 4–4(5); these rows are preceded by fairly long seta near base of scape. Pronotum with 1 row of 6 large setae per side (Fig. 5). Pronotal comb with 14 fairly broad spines. Mesonotum with 3 rows of setae, last row larger than the others. Mesonotal flange with 3 pseudosetae per side. Mesepisternum 2 short median setae and long submedian one. Mesepimeron 5 setae, longest near ventral margin. Metanotum 3 rows of setae; anterior third row 2–3 small setae. Metepisternum 2 setae near posterodorsal angle; 1 very long. Metepimeron 6 setae (3–1–2), anterior row of 3 thin setae and posterior longer group of 3. Profemur with 11–12 small thin lateral setae. Longest setae of tarsus of foreleg on segment I, where 2 dorsolateral setae reach apex of second segment. Second segment of metatarsus bearing apical seta extending to base of fifth segment. Tergites with apical spinelets (4–4–4–3–1). Two antesensillar setae (Fig. 10), dorsal almost twice as long as ventral. Sternite VIII of male (Fig. 10) with long lateral seta and 2 long thin setae per side near ventrocaudal angle; 8–9 shorter setae anterior mainly marginal; posterior margin slightly sinuate. Fixed process of clasper (Fig. 14) as high as long (broad), biconvex, dorsomarginal row of thin setae with few gaps in the region between the humps, and subapical mesal patch of 6 small thin setae; lateral margin with row of thin setae until beyond the middle. Sclerotized process above acetabular region pointed, with 1 subdorsal seta and 2 apicomarginal setae. Movable process (Fig. 14) slightly more than twice as long as broad at maximum; anterior margin almost straight; caudal



60



61

FIGURES 60–61. (60) *Strepsylla* species distribution map: black triangle *S. queretana*; white triangle *S. vargasi*; black square *S. longicauda*; white square *S. tezontli*; black circle *S. taluna*; white circle *S. fautini*; asterisk *S. davisae*. (61) *Strepsylla* species distribution map: black circle *S. ixtlanensis*; white circle *S. villai*; black square *S. mina*; white square *S. schmidtii*; black triangle *S. machadoi*.

margin evenly rounded from apex to end (base); ventral margin quite straight. Movable process with caudomarginal row of setae from apex to near base, and group of 3 lateral and mesal stout setae; apical half with thin scattered small setae, some submarginal. Apex of proximal arm of sternite IX with margin straight; the dorsocaudal angle expanded and rounded, equal in length to the acute anterodorsal angle. Distal arm of

sternite IX (Fig. 27) longer than proximal arm; apex truncate and sickle-shaped, with 2 long slender setae, with broad spiniform bristle; apex is bent into a claw shape; below these a slender seta, and row of thin submarginal setae below; semi-membranous flap rounded and spiculose apically, longer than distal arm. This flap with proximal curved (looped) spiniform bristle; thin seta distal to spiniform bristle and row of short,



FIGURE 62. Distribution map of *Strepsylla dalmati*.

marginal setae proximal to it (Fig. 27). Aedeagal apodeme 4 times as long as broad. Base of well-developed aedeagal pouch wall sclerotized, with lobe. Ventral margin of wall of aedeagal pouch sclerotized and apically with distinct ventral hump. Median dorsal lobe with apex truncate. Subapical dorsal lobe fairly differentiated. Distodorsal lobes developed, 3 times as long as broad; apically truncate. Lateral lobes of aedeagus apically rounded extending beyond apex of crochet. Crochets longer than broad (Fig. 40); proximal portion slender; dorsally produced into a long broad arm; sclerotized portion appearing apically rounded but actually lightly sclerotized apically. Lobes of apodemal strut differentiated and apex truncate. Sternite VII of females with shallow, fairly broad sinus near ventral margin (Fig. 57); row of about 5 long setae, preceded by 6 smaller setae and 3–4 ventromarginal small setae. Tergite VIII with group of 6–7 setae above long thin spiracle; this group extending ventral as row of 2 small setae and median; long seta at level of dorsal anal lobe; ventrocaudal region of eighth tergite with setae as follows: 4 long setae bordering subventral sinus; with submedian seta; below 3–4 small lateral setae; between these last 2 groups of setae, a patch of about 10 small, fairly thick mesal setae. Sternite VIII represented as conical structure bearing 1–2 tiny subapical dorsomarginal setae. Dorsal anal lobe of proctiger with dorsomarginal fringe of small setae and about 12 scattered setae, of which the ventromarginal subapical 1 is long, as is 1 seta inserted at base of anal stylet. Ventral anal lobe not heavily sclerotized nor angulate; with about 7 fairly evenly spaced marginal setae, 5 of which are long. Anal stylet almost 3 times as long as broad; with small dorsomarginal seta and 1 long apical seta. Spermatheca (Fig. 57) with hilla longer than bulga; hilla upturned over the bulga (C shaped); bulga longer than broad. Bursa copulatrix fairly well developed, with apex (that portion adjoining spermathecal duct) relatively weakly sclerotized.

**Taxonomic summary**

*Type host:* *Peromyscus* sp.

*Type locality:* Mexico. Nuevo León. 7.4 km S, 0.2 km W San Josecito, 2,670 m.

*Types:* Holotype male ECMV 2200, 13/VI/1991, M. Vargas, deposited in Acarologia Lab., IBUNAM. Paratypes: Mexico. 15/VI/1991, M. Vargas, ECMV 2614, 1 male ex *Sigmodon*, 3 females ex *Peromyscus*, M. Vargas. ECMV 2620, ECMV 2624, ECMV 2631 (IBUNAM). Zacatecas. 4.3 km N, 5.4 km E San Juan Capistrano, 1,250 m, 21/XII/1987, 1 male ex

*Peromyscus*, M. Vargas, ECMV 542 (IBUNAM). Nuevo León. 7.4 km S, 0.2 km W San Josecito, 2,670 m, 13/VI/1991, 2 males, 1 female ex *Peromyscus*, M. Vargas, ECMV 2215 (IBUNAM); 5.2 km N, 0.2 km W San Josecito, 1,600 m, 14/XI/1990, 1 female ex *Peromyscus*, M. Vargas, ECMV 2261 (IBUNAM). Deposited in IBUNAM.

*Etymology:* The species is named for Margarita Vargas, who collected the specimens.

*Distribution:* Northern Mexico (Fig. 60).

**Remarks**

This new species is separable from all known *Strepsylla* by a movable process (Fig. 14). Moreover, it is more slender than *S. taluna*, with a scattered row of setae in dorsal margin (Fig. 23). Neither the host preference nor the distribution can be accurately inferred with the existing data.

***Strepsylla queretana* n. sp.**

(Known only from male[s]) (Figs. 3, 8, 15, 28, 41, 60)

*General diagnosis:* Distal arm of sternite IX narrow, apex almost sickle-shaped, slender and pointed, with 2 setae and lateral long stout spiniform bristle; flap of sternite IX with robust long curly spine, and apex micropunctuated (Fig. 28); base of lateral lobes wide, narrow, and rounded toward apex. Movable process with few slender setae in dorsal margin.

First pre-antennal row with 5 small setae in males (Fig. 3); second row of 4 long setae; third seta nearest eye shorter than others. Maxillary lobe extending to apex of third segment of maxillary palp. Pedicel with apical fringe of small setae, not extending beyond second segment of symmetrical club. Post-antennal region with 2 rows of setae (4–4), preceded by a fairly long seta near base of scape. Pronotum with 1 row of about 5 large setae per side (Fig. 3). Pronotal comb with 12 fairly broad spines. Mesonotum with 2 rows of setae, preceded by scattered short setae; setae of last row much larger than the other. Mesonotal flange per side 2 pseudosetae. Mesepisternum with 3 short median setae and a long ventral margin. Mesepimeron with 4 setae, longest near ventral margin. Metanotum with 2 rows of setae; last row much longer than the other. Metepisternum with 7 setae near posterodorsal angle; 3 very long, the others very short. Profemur with 9–10 small thin lateral setae. Second segment of metatarsus bearing apical seta extending to base of segment 5. Tergites with apical

spinelets as follows: 4–6–4–4. Two antesensillial setae (Fig. 8), dorsal longer than ventral. Sternite VIII (males) with row of 3 long setae per side near ventrocaudal angle (Fig. 8), 1 of them longer than the others; 9–10 shorter setae anterior to row, mainly marginal; posterior margin slightly sinuate. Fixed process of clasper (Fig. 15) broad, almost square, with dorsomarginal row of thin setae, caudomarginal row of similar but widely spaced setae in both margins, and subapical mesal patch of about 5 small stout setae; dorsal margin biconvex. Sclerotized process above acetabular region large and truncate, with 1 subdorsal seta and 2 apicomarginal setae. Movable process (Fig. 15) slightly more than twice as long as broad at maximum; anterior low margin concave and apical margin almost straight; caudal margin evenly rounded from apex to end point; ventral margin straight. Movable process with caudomarginal row of setae from apex to beyond midpoint toward end, and group of mesal thin setae at level of midline; apical half with thin scattered small setae, some submarginal. Apex of proximal arm of sternite IX with margin almost straight; dorsocaudal angle expanded and semi-rounded. Distal arm of sternite IX as long as proximal arm; apex sickle-shaped, tapering, and bearing 2 long slender setae, with long broad spiniform bristle; stout seta, and subapical group of thin median and submarginal setae below these; semi-membranous flap spiculose apically (Fig. 28). This flap with curved (looped), spiniform bristle; thin seta distal to spiniform bristle on flap (Fig. 28). Aedeagal apodeme 3 times as long as broad. Base of well-developed pouch wall sclerotized, with conspicuous lobe. Ventral margin of wall of aedeagal pouch sclerotized, almost straight, and apically with a distinct ventral hump. Median dorsal lobe slender, shallowly sinuate. A broad, round, cordate sclerite present. Subapical dorsal lobe fairly well differentiated. Distodorsal lobes well developed, 2 times as long as broad, from apex of the cordate sclerite, apically subtruncate; lateral lobes conspicuous, extending slightly beyond apex of dorsal lobe, apically rounded. Crochets longer than broad; proximal portion broadly ovate; dorsally produced into a long broad spur; sclerotized portion apically, dorsally convex extending to apex (Fig. 41).

#### Taxonomic summary

*Type host:* *Peromyscus difficilis* (Allen 1891).

*Type locality:* Mexico: Querétaro, Maguey Verde, 2,290 m.

*Types:* Holotype male (03646MZFC-S), 24/II/1983, E. Romo. Deposited in MZFC-S.

*Etymology:* The species is named for the Mexican state where the specimen was collected: Querétaro.

*Distribution:* Central Mexico (Fig. 60).

#### Remarks

The base of lateral lobes is wide, similar to *S. fautini* (Fig. 44), but narrow and rounded toward the apex; the dorsal lobes are wide, with a slightly deep cleft near the apex, similar to *S. dalmati* (Fig. 42). The crochet is similar to *S. ixtlanensis* (Fig. 41), but the apex is not rounded. There is a movable process with a few slender setae in dorsal margin, as for *S. taluna* (Fig. 23). Neither the host preference nor the distribution can be accurately inferred with the existing data.

## DISCUSSION

#### Comparative notes

The male genital structures are useful for identifying the species in this genus. The females are difficult, if not impossible, to identify with any degree of accuracy in the absence of accompanying males. The genus can be divided into species groups, based on distinctive morphological characters. One group (*S. fautini* and *S. dalmati*) is distinguished by the shape of crochet, which has almost a 90° angle between the proximal and distal ends. In another group (*S. villai*, *S. mina*, and *S. tezontli*), the length of the end arms of the crochet are equal, forming an inverted C-shape. *Strepsylla davisae*, *S. taluna*, and *S. longicauda* form a third group in having the upper arm of the crochet longer

and narrower than the lower short arm. *Strepsylla ixtlanensis*, *S. queretana*, and *S. vargasi* can be grouped based on the upper arm of the crochet being longer and wider at the apex than the lower shorter apically truncate arm. Two species, *S. machadoi* and *S. schmidtii*, are distinguished by differences in crochet shape from the other species (Figs. 45, 47). *Strepsylla machadoi* has just 1 arm of the crochet with a wide apex, and *S. schmidtii* has a U-shape form with 1 arm longer than the other.

The structure of sternite IX is similar in some species. *Strepsylla fautini* and *S. longicauda* present this structure as truncate or almost rounded, with a long stout spinelet. *Strepsylla villai*, *S. mina*, *S. tezontli*, and *S. taluna* have a sickle-shaped and hooked apex of sternite IX, with a short stout spinelet, while *S. vargasi* and *S. queretana* have the same shape, and a long stout spinelet. Other species are similar but have some differences, as in *S. schmidtii*, *S. dalmati*, and *S. ixtlanensis*, which have an incompletely pointed apex, or *S. machadoi*, which presents an apex that is truncated and wider than other species. The majority of the species have a looped spiniform bristle on the flap of sternite IX, although in *S. dalmati*, *S. schmidtii*, and *S. machadoi*, this stout seta is bent, not completely curly or looped (Figs. 29, 32, 34).

Some of the modifications found in *S. machadoi* are more noticeable than in the other species of the genus, i.e., a fixed process, crochet, setae of the flap, the apex of sternite IX, and the middle constriction in the aedeagal apodeme. These characters place the species near the base of the cladogram (see next section), next to the *Epitedia* and *Neopsylla* outgroups (Fig. 59).

#### Cladistics and biogeography

One maximum parsimony tree was constructed (Fig. 59) with 86 steps, a consistency index of 0.36, and a retention index of 0.50. The cladogram consists of 2 major lineages. One includes *S. vargasi* + *S. tezontli* and the sister species *S. mina* and *S. villai*. This clade is supported by characters 3 and 8. The other major clade, supported by character 15, includes the basally placed *S. queretana* and 2 further divisions, i.e., *S. fautini* and *S. ixtlanensis*, which are supported by character 22, and the *S. taluna* + *S. longicauda* + *S. davisae* group, in which the latter species is basal. The remaining 3 species of the genus, *S. machadoi*, *S. dalmati*, and *S. schmidtii*, are basally placed as individual terminal taxa.

According to Lewis (1974), the genus *Strepsylla* has a Nearctic distribution pattern. However, Medvedev (2000a, 2000b) considered the genus as endemic to the Caribbean subregion of the Neotropics. If we observe the cladogram (Fig. 59) from a biogeographic point of view, the basal species are distributed in the south; the most southern distribution known for the genus is in Panama, where *S. dalmati* is found, as well as Guatemala, Honduras, and Costa Rica (Fig. 62). Continuing to the north, *S. schmidtii* is found in Chiapas State, *S. ixtlanensis* is in Oaxaca, and *S. machadoi* is in Guerrero State (Fig. 61). *Strepsylla dalmati*, *S. schmidtii*, and *S. machadoi* constitute a paraphyletic group placed at the base of the cladogram, except for *S. ixtlanensis*, which is placed in another group, and *S. fautini* is distributed in the Trans-Mexican Volcanic Belt, in Michoacán. The latter two species are related to another clade that includes *S. taluna* (central Mexico), *S. longicauda* (northern Mexico), and *S. davisae* (northern Mexico) (Fig. 60).

The clade including *S. mina* and *S. villai* (Fig. 59) is distributed in central Mexico, Distrito Federal and the Popocatepetl volcano

surroundings. It is related to *S. tezontli*, which is found on the Popocatepetl volcano (Fig. 61), followed by *S. vargasi*, which is distributed in northern Mexico (Nuevo León and Zacatecas). The species of the first clade are distributed in the Trans-Mexican Volcanic Belt, except *S. vargasi* and the species grouped at the base of the tree, representing the southern distribution of the genus (Figs. 60, 61).

Biogeographically, the species are clustered in south-central Mexico, with the exception of *S. longicauda* and *S. davisae*, which occur further north in Durango (Fig. 60), *S. ixtilanensis* and *S. schmidti* to the south of Mexico in Oaxaca and Chiapas (Fig. 61), and *S. dalmati* even further south in Panama, Honduras, Costa Rica, and Guatemala (Fig. 62). The cladogram, the current distributional records, and the ecological preferences of hosts of *Strepsylla* species support Lewis' (1974) statement that the genus corresponds to a Nearctic distribution pattern. Most of the host species are distributed in montane forest, and show Nearctic affinities in their mammal components. More research is necessary to elucidate the mode of speciation, systematics, and biogeography of *Strepsylla*. Gaps in our knowledge of the distribution of the genus are evident, and undiscovered new species probably exist in the mountain regions of Guatemala, El Salvador, Honduras, Nicaragua, Costa Rica, and Panama, where the flea fauna is particularly unexplored.

Host-parasite relationships in this flea genus, as Lewis (1974), Lewis and Lewis (1985), and Medvedev (2000a, 2000b) stated, show a host preference for peromyscine rodents; the majority of the flea specimens were collected on 7 different species of *Peromyscus*, and only a few records from 5 genera of Murinae and 1 genus of Sciuridae are noted. Because of shared distribution with several *Peromyscus* species and with the volcano mouse *Neotomodon alstoni*, I consider the record from *Romerolagus diazi* (volcano rabbit) as accidental. However, likely changes in host preferences could suggest that species of *Strepsylla* adapted to the change in the rodent fauna and are subject to host switching based on sympatry.

#### ACKNOWLEDGMENTS

I thank Juan J. Morrone, Jesús A. Fernández, Jeens Prena, Michael W. Hastriter, and Ralph P. Eckerlin for comments on the manuscript, as well as the curators who loaned the specimens and type material studied herein: John E. Rawlins, Carnegie Museum of Natural History, Pittsburgh; Theresa Howard, The Natural History Museum, London; Michael W. Hastriter, Brigham Young University, Provo, Utah; Nancy Adams (deceased) and David G. Furth, National Museum of Natural History, Smithsonian Institution, Washington, D.C.; Prof. Ralph P. Eckerlin, Northern Virginia Community College, Annandale, Virginia; James H. Boone, Field Museum of Natural History, Chicago; Juan J. Morrone, Museo de Zoología, Facultad de Ciencias, Universidad Nacional Autónoma de México, Mexico, D.F.; and Margarita Vargas. Thanks are due to Jesús A. Fernández for hand carrying material from the United States. I also wish to thank CONACyT (grant 200243) for supporting my

doctoral studies, and the Museo de Zoología for provision of working space, equipment, supplies, and general support required for this work.

#### LITERATURE CITED

- ACOSTA, R. 2010. Estudio sistemático de la tribu Phalacropsyllini (Siphonaptera: Ctenophthalmidae: Neopsyllinae), con énfasis en el género *Strepsylla*. Ph.D. Thesis. Facultad de Ciencias, UNAM, México, D.F., 80 p.
- , AND J. A. FERNÁNDEZ. 2007. Fauna de pulgas y sus huéspedes. In Biodiversidad de la Faja Volcánica Transmexicana, I. Luna, J. J. Morrone, and E. Espinosa (eds.). UNAM, México, D.F., p. 357–370.
- ADAMS, N. E., AND R. LEWIS. 1995. An annotated catalog of primary types of Siphonaptera in the National Museum of Natural History, Smithsonian Institution. Smithsonian Contributions to Zoology **560**: 1–86.
- BARRERA, A., AND R. TRAUB. 1963. Notas sobre sifonápteros X—Descripción de *Strepsylla machadoi* nov. sp. (Siph. Hystrichops., Neops.). Ciencia (Mex.) **2**: 191–196.
- GOLOBOFF, P. A. 1996. NONA ver. 2.0. Software distributed by Fundación e Instituto Miguel Lillo, San Miguel de Tucumán, Argentina.
- HOPKINS, G. H., AND M. ROTHSCHILD. 1962. An illustrated catalogue of the Rothschild collection of fleas (Siphonaptera) in the British Museum (Natural History): III. Hystrichopsyllidae (Acedestiinae, Anomiopsyllinae, Hystrichopsyllinae, Neopsyllinae, Rhadinopsyllinae and Stenoponiinae). British Museum of Natural History, London, U.K., 560 p.
- JORDAN, K. 1937. On some North American Siphonaptera. Novitates Zoologicae **40**: 262–271.
- . 1938. On some Nearctic Siphonaptera. Novitates Zoologicae **41**: 119–124.
- LEWIS, R. E. 1974. Notes on the geographical distribution and host preferences in the order Siphonaptera. Journal of Medical Entomology **11**: 147–167.
- , AND G. E. HAAS. 2001. A review of the North American *Catallagia* Rothschild, 1915, with the description of a new species (Siphonaptera: Ctenophthalmidae: Neopsyllinae: Phalacropsyllini). Journal of Vector Ecology **26**: 51–69.
- , AND J. H. LEWIS. 1985. Notes on the geographical distribution and host preferences in the order Siphonaptera. Journal of Medical Entomology **22**: 134–152.
- MEDVEDEV, S. G. 2000a. Fauna and host-parasite associations of fleas (Siphonaptera) in different zoogeographical regions of the world: I. Entomological Review **80**: 409–435.
- . 2000b. Fauna and host-parasite associations of fleas (Siphonaptera) in different zoogeographical regions of the world: II. Entomological Review **80**: 640–655.
- MORRONE, J. J. 2006. Biogeographic areas and transition zones of Latin America and the Caribbean Islands based on panbiogeographic and cladistic analyses of the entomofauna. Annual Review of Entomology **51**: 467–494.
- NIXON, K. C. 2002. WinClada ver. 1.00.08. Published by the author, Ithaca, New York.
- ROTHSCHILD, N. C. 1915. On *Neopsylla* and some allied genera of Siphonaptera. Ectoparasites **1**: 30–44.
- TRAUB, R. 1950. Siphonaptera of Central America and Mexico. A morphological study of the aedeagus with descriptions of new genera and species. Fieldiana Zoology **1**: 1–27.
- , AND A. BARRERA. 1955. Three new fleas of the genus *Strepsylla* Traub (Siphonaptera: Hystrichopsyllidae). Fieldiana Zoology **37**: 541–550.
- , AND P. T. JOHNSON. 1952. Four new species of fleas from Mexico (Siphonaptera). American Museum Novitates **1598**: 1–28.